

# IntelliSAW CAM™ Platform Sensors

## INSTALLATION MANUAL



### Temperature

Addresses thermal breakdown



### Partial Discharge

Addresses insulation breakdown



### Humidity

Addresses air dielectric breakdown

Document: 910.00379.0001

Revision: 1.0

Date: 19 September, 2016

**Copyright © 2016, IntelliSAW**

IntelliSAW reserves the right to make technical changes or modify the contents of this document without prior notice. IntelliSAW is not responsible for errors or possible lack of information in this document.

IntelliSAW reserves all rights in this document and in the subject matter and illustrations contained therein. Any reproduction, disclosure to third parties or utilization of its contents, in whole or in part, without prior written consent of IntelliSAW is forbidden.

**IntelliSAW**  
Rosemount Measurement  
100 Burt Rd.  
Andover, MA 01810  
+1-978-409-1534



**WARRANTY**

These products are warranted to be free from functional defects in material and workmanship at time of manufacture and to conform at that time to the specifications set forth in the relevant instruction manuals or data sheets, for such products for a period of one year.

*Reference IntelliSAW terms and conditions provided at time of purchase for complete warranty details.*

## IMPORTANT INFORMATION



This symbol identifies messages in this document related to safety.



### **DANGER**

DANGER indicates an imminently hazardous situation, which, if not avoided, will result in death or serious injury.

**Failure to follow the instructions given will result in death or serious injury.**



### **WARNING**

WARNING indicates a potentially hazardous situation, which, if not avoided, could result in death or serious injury.

**Failure to follow the instructions given can result in death or serious injury**



### **CAUTION**

CAUTION indicates a potentially hazardous situation, which, if not avoided, may result in minor or moderate injury.

**Failure to follow these instructions can result in personal injury.**

### **NOTICE**

NOTICE alerts you to practices unrelated to personal injury, such as those that can cause property damage.

**Failure to follow these instructions can result in property damage.**

### **IMPORTANT**

IMPORTANT indicates additional information about making effective use of this product.

## TABLE OF CONTENTS

1	Introducing the IntelliSAW CAM™ Platform Sensors .....	6
1.1	IntelliSAW System Architecture.....	6
2	SAW Temperature Sensors .....	7
2.1	Specifications.....	7
2.2	Dimension and Mounting .....	8
2.3	Labeling .....	8
2.3.1	Band Identification and Cal Code.....	8
2.4	Grouping.....	9
3	CAM™ Air Interfaces .....	10
3.1	TMP Air Interface – Temperature Only.....	10
3.1.1	Specifications.....	10
3.1.2	Dimensions.....	11
3.2	TPD Air Interface – Temperature and Partial Discharge.....	11
3.2.1	Specifications.....	12
3.2.2	Dimensions.....	13
3.3	Labeling .....	13
3.3.1	Front (digital print).....	13
3.3.2	Back Label.....	14
3.4	Mounting.....	14
3.5	Cabling .....	15
3.5.1	Impact of Cable Length on Read Range .....	15
4	Humidity & Ambient Temperature Sensor .....	16
4.1	Specifications.....	16
4.2	Dimensions.....	17
4.3	Label.....	17
4.4	Mounting Options.....	17
4.5	Wiring .....	18
4.5.1	Single Connection.....	18
4.5.2	Series Connect .....	19
4.5.3	Star Connect.....	19
5	Installation.....	20
5.1.1	Typical Installation .....	20
5.2	Temperature Sensor / Air Interface Installation .....	22

---

5.2.1	Required Hardware.....	22
5.2.2	Basic Insulation Level (BIL).....	22
5.2.3	RF Isolation and Maximum Sensor Count.....	23
5.2.4	Sensor Arrangements.....	23
5.2.5	Mounting Temperature Sensors.....	24
5.2.6	Radiation Patterns .....	25
5.2.7	Air Interface Installation .....	29
5.2.8	Optimizing Signal Strength & Configuring the System.....	29
5.2.9	SAW Temperature Calibration .....	30
5.3	Partial Discharge Configuration.....	31
5.4	Humidity / Ambient Sensor Installation.....	31
5.4.1	Mounting.....	31
5.4.2	Humidity Sensor Wiring .....	31
5.5	Outdoor Asset Installation with Environmental Enclosures.....	32
Contact	.....	33

# 1 INTRODUCING THE INTELLISAW CAM™ PLATFORM SENSORS

The IntelliSAW Critical Asset Monitoring (CAM™) Platform monitors the three main failure modes of electrical power critical assets. A CAM™ system consists of a monitoring unit (CAM-4 or Reader) and three types of sensors:

- **Wireless SAW Temperature:** addresses thermal breakdown
- **Partial Discharge:** addresses insulation breakdown
- **Humidity / Ambient Temperature:** addresses air dielectric breakdown

## 1.1 INTELLISAW SYSTEM ARCHITECTURE

IntelliSAW monitoring units (Reader or CAM-4) can accept the following MAXIMUM sensor configuration:

- 12 wireless SAW temperature sensors
- 4 air interfaces (Temp only or Temp & PD)
- 8 humidity / ambient temperature sensors (series connected)

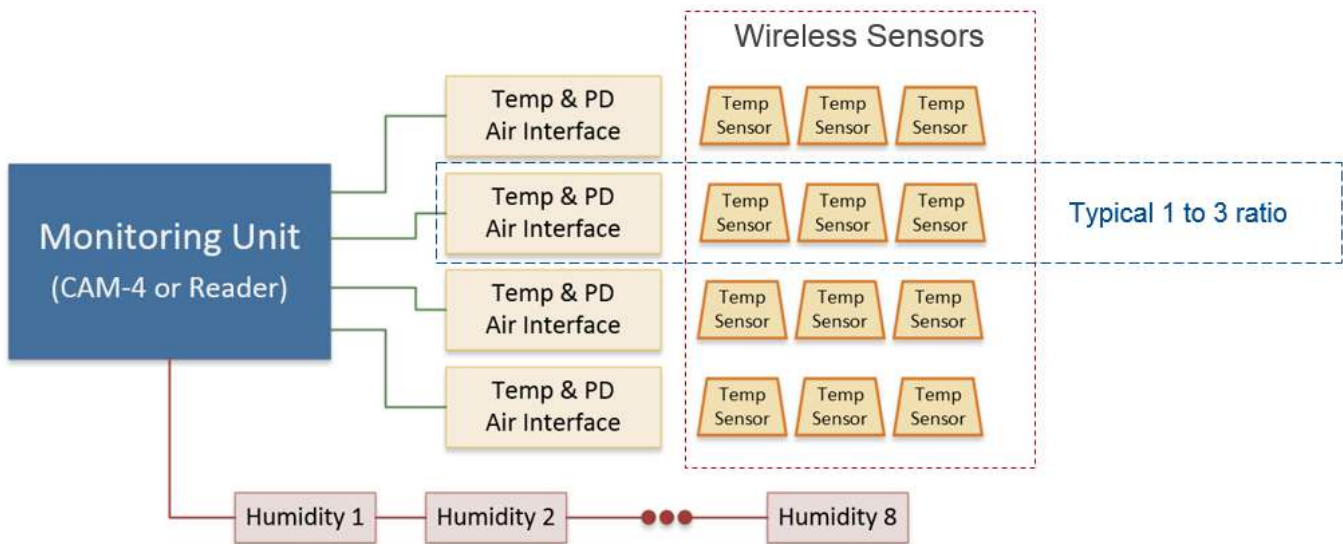

Figure 1: IntelliSAW System Overview

## 2 SAW TEMPERATURE SENSORS

Wireless, passive Surface Acoustic Wave (SAW) temperature sensors are directly mounted to asset critical measurement locations. Radio Frequency (RF) interrogation signals between monitoring units / air interface and sensors are used to determine the temperature.



### 2.1 SPECIFICATIONS

#### Temperature Measurements

Range	-25°C to +125°C
Resolution	± 0.2°C
Accuracy	
Standard Range (0 to 80°C)	± 2°C
Full Range	± 4°C
Number of Sensor Channels	12 (non-overlapping channels)
Sensor Frequencies	Between 425 MHz to 442MHz

#### Physical

Base Plate Material	260 Brass, Tin Plated
Cover Material	Polycarbonate, UL94-HB
International Protection (IEC 60529)	IP 30
Cover Dielectric Strength	15 KV
Dimensions	30.5W x 53.5 L x 35.5 mm H

#### Mounting

Bolt (Max)	13 mm or ANSI ½ in.
Mounting Torque (Max)	102 N-m (75 lb-ft) Use asset manufacturer's recommended bolt torque at all times. A high strength flat washer between the nut and the sensor must be used.
Alternate Solutions	<b>Cable Tie: 5.5 W x 1.65 mm Thick (Max)</b> Non-conducting ETFE, 150°C operating temperature (McMaster-Carr 70215K93) <b>Bonding Tape</b> 3M VHB 4646 Bonding Tape (150°C operating temperature)

#### Type Testing

Units were installed on switchgear critical locations while the switchgear was subjected to the following testing:

IEC 62271-100	MV Switchgear, Voltage withstand: 95 kV/1m, 185 kV impulse
IEC 62271-200	MV Switchgear, Short circuit withstand: 63 kA/3s, 171 kA impulse

## 2.2 DIMENSION AND MOUNTING

SAW Temperature sensor dimensions are 30.5W x 53.5 L x 35.5 mm H. The recommended mounting method is to bolt mount with an existing asset bolt, although alternative mounting solutions such as heat resistant tie wraps or heat resistant tap can be used.

**For details on installation methods and specifications:** [5.2 Temperature Sensor / Air Interface Installation](#)

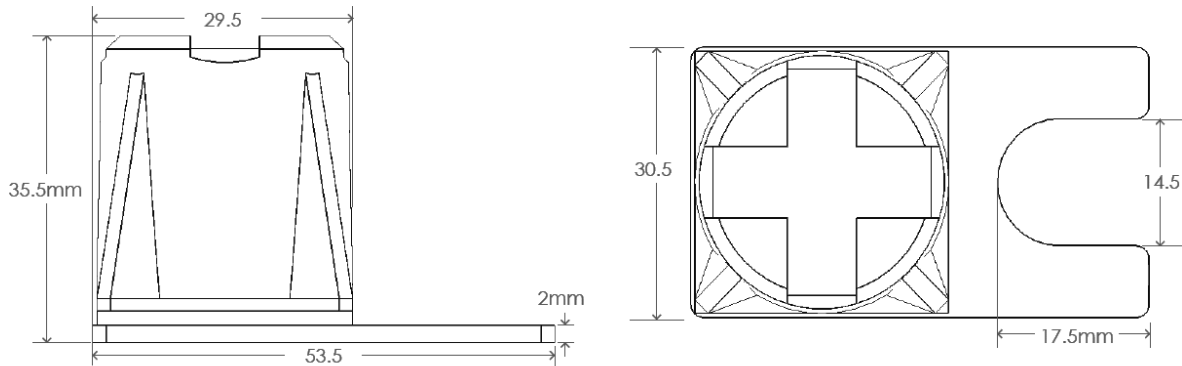

Figure 2: Temperature Sensor Dimensions

## 2.3 LABELING

SAW Temperature sensors have 4 types of labels (sensor ID, sensor ID with barcode, sensor serial number, and China RoHS)

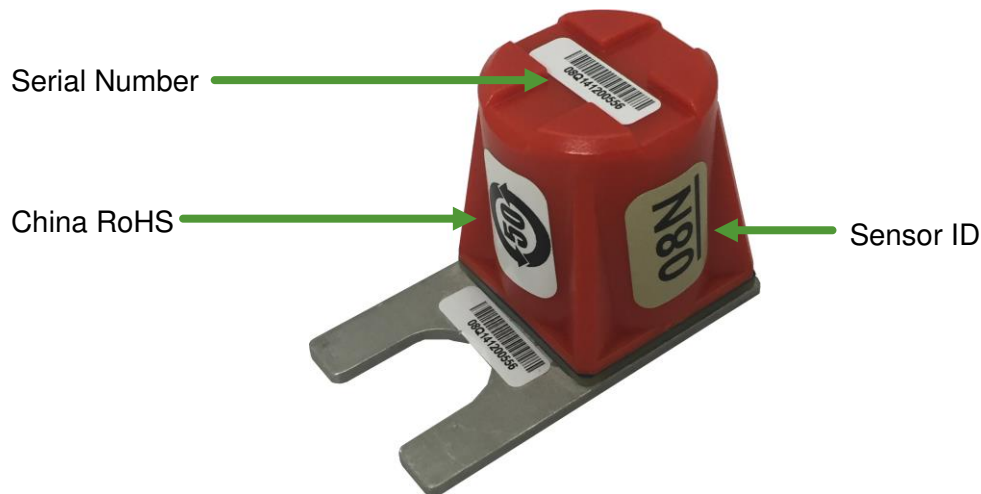

Figure 3: Sensor Labels (Sensor ID with barcode not shown)

### 2.3.1 Band Identification and Cal Code

The SAW Temperature sensors have 12 unique band numbers and are grouped by color codes to ensure optimal performance along with easy installation and visualization in electrical power



assets. They also contain a calibration letter which will be used during configuration. In the sensor example above, the identification would be **Band: 08, Cal Code: N**.

**The Band Identification and Cal Code are required when configuring a monitoring unit for temperature measurements.**

## 2.4 GROUPING

Sensors are grouped with unique color codes (Sensor ID Labels) to support easy installation and visualization in electrical power assets. When commissioning a system, care must be taken not to duplicate same sensor frequency bands within a given asset or in the common bus of adjacent assets. IntelliSAW recommends selecting sensors based on their groupings for optimal performance. The color codes may also be used as a short-hand notation in system single-line drawings to denote a group of sensors.

Identification Bands	Sensor Group Color
01, 03, 05	Orange
02, 04, 06	White
07, 09, 11	Dark Gray
08, 10, 12	Tan



Figure 4: Example Labels

### 3 CAM™ AIR INTERFACES

IntelliSAW Air Interfaces provide optimal signal performance for measuring passive SAW temperature sensors and detecting Partial Discharge (PD) with immunity from induced power frequencies. Reading distances compatible with basic insulation levels (BIL) up to 185kV.



There are two CAM™ Air Interfaces models:

- **TMP:** used only for SAW temperature sensor interrogation
- **TPD:** used for SAW temperature sensor interrogation and PD monitoring

The air interfaces are directly connected to a monitoring unit through shielded coaxial cable and are to be attached to earthed enclosure metal for safety.

#### 3.1 TMP AIR INTERFACE – TEMPERATURE ONLY

##### 3.1.1 Specifications

###### General Specifications

Span	425 MHz – 442 MHz
Return Loss	-7db maximum
Gain	+3.0 dBi, typical
Impedance	50 $\Omega$ , nominal
Dimensions	118 W x 134.5 L x 34.45 mm H (4.65 x 5.3 x 1.36 in.)
Material	ABS UL 94 V-0, black
Weight	0.2 kg (0.45 lb)
Mounting	<b>Magnetic:</b> 4 magnets, 32.6 kg (72 lb) pull force <b>Bolt mount:</b> 4 x 4.8 mm eyelets
Interface Connector	SMA
International Protection (IEC 60529)	IP 40
Operating Condition	-25°C to + 70°C, 10 – 95% RH non-condensing

### 3.1.2 Dimensions

The TMP Air Interface is 118 W x 134.5 L x 34.45 mm H (4.65 x 5.3 x 1.36 in.).

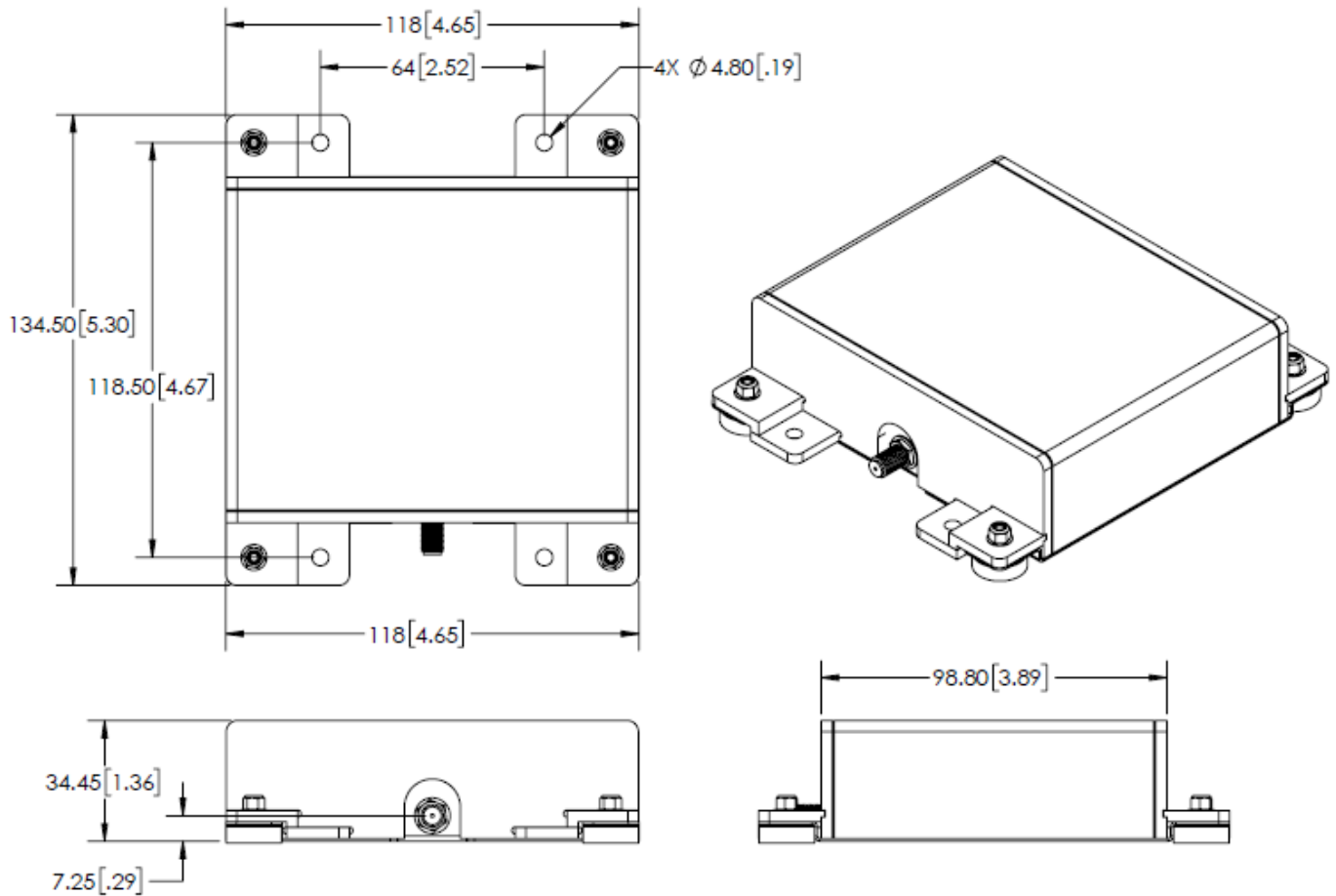

Figure 5: TMP Dimensions

### 3.2 TPD AIR INTERFACE – TEMPERATURE AND PARTIAL DISCHARGE

The TPD Air Interface combines SAW temperature sensing and Partial Discharge detection. This broad band antenna is optimized for UHF radio detection methods at three distinct bands with center frequencies of 300 MHz, 600 MHz, and 1200 MHz while still providing capabilities for SAW sensor detection at 433 MHz. The CAM air interface affords multiple opportunities to recognize internal and surface discharges associated with the onset of critical asset insulation failures and to distinguish these events from noise sources.

### 3.2.1 Specifications

#### General Specifications

Span	250 MHz – 2 GHz
Return Loss	See Figure 4 for details
(1) At 300 MHz	Reflective
(2) At 425 MHz	-16 dB, max
(3) At 442 MHz	-10 dB, max
(4) At 600 MHz	Reflective
(5) At 1200 MHz	-16 dB, max
Gain	+3.5 dBi, typical
Impedance	50 $\Omega$ , nominal
Dimensions	198 W x 167 L x 43 mm H (7.8 x 6.6 x 1.7 in.)
Material	ABS UL 94 V-0, black
Weight	0.57 kg (1.25 lb)
Mounting	<b>Magnetic:</b> 4 magnets, 50.8 kg (112 lb) pull force <b>Bolt mount:</b> 6 x 4.8 mm eyelets (magnets must be removed)
Interface Connector	SMA
International Protection (IEC 60529)	IP 40
Operating Condition	-25°C to + 70°C, 10 – 95% RH non-condensing

### 3.2.2 Dimensions

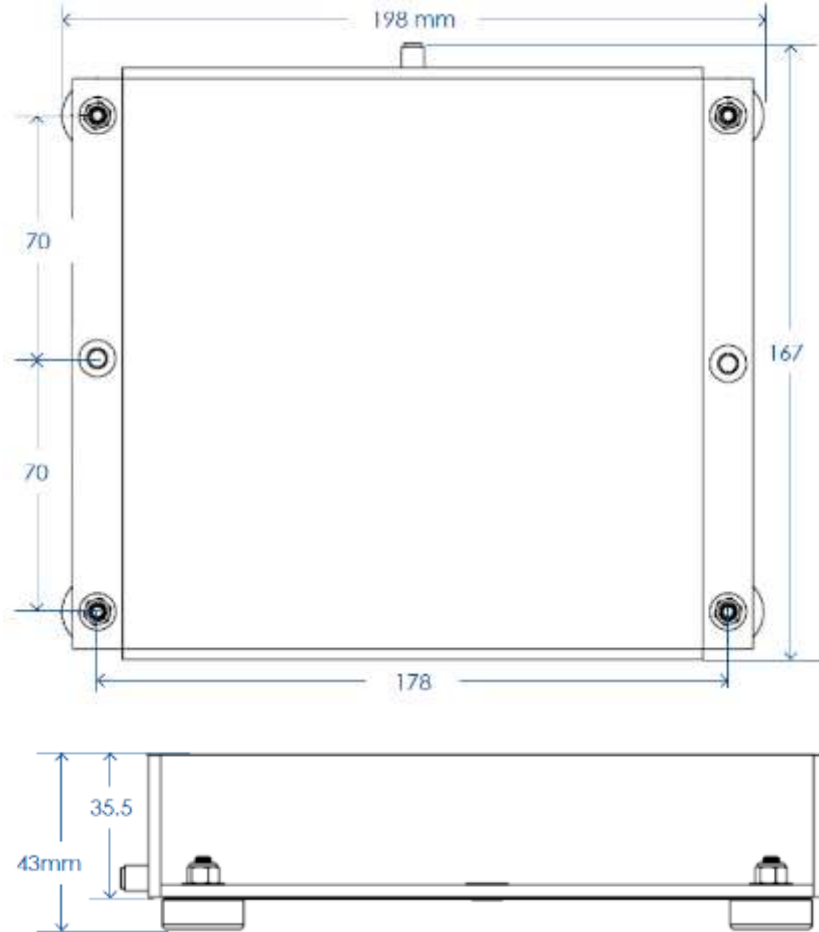

Figure 6: Air Interface Dimensions

## 3.3 LABELING

### 3.3.1 Front (digital print)

The front of each air interface provides the product logo (IntelliSAW), platform (Critical Asset Monitoring) device type (Air Interface) and application the units can be used for:

- Temperature
- Temperature and Partial Discharge



Figure 7: TPD and TMP Air Interfaces - Front print

### 3.3.2 Back Label

The back label contains the model number and serial number of the Air Interface.

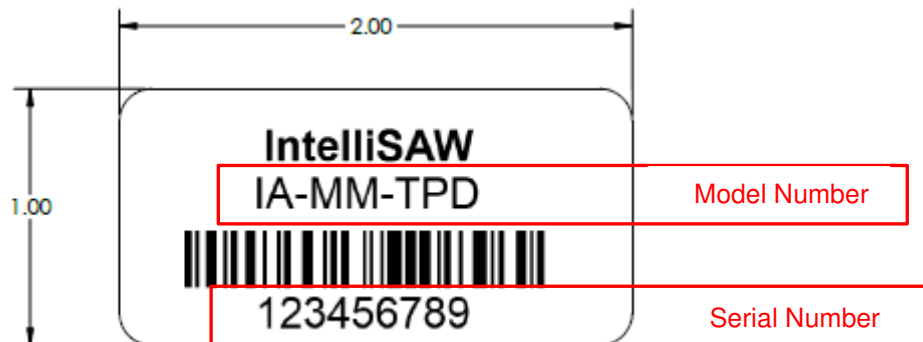

Figure 8: Air Interface Back Label

## 3.4 MOUNTING

All air interfaces use Neodymium rare-earth magnets, the strongest and most permanent magnets known to man. If they are not overheated or physically damaged, neodymium magnets lose less than 1% of their strength over a 10 year period and less than 5% over a typical asset lifetime. Magnets are the optimal solution for locating the air interface to ensure proper signal strength to the SAW sensors.

**After the final air interface location has been determined, the units can be bolt mounted if chosen.**

## 3.5 CABLING

IntelliSAW uses the highest quality double-shielded coaxial cables to ensure no signal degradation during data acquisition. The cables are assembled with the required SMA connectors to interface from an air interface to an IntelliSAW monitoring unit.



### 3.5.1 Impact of Cable Length on Read Range

SAW passive wireless sensors are linear systems and the fundamental limitation for the SAW-based identification system occurs when the received signal level at the reader becomes too weak for reliable detection. With RF signals, as the cable length increases, read range decreases, and therefore there are cable length restrictions. The average loss of read range is 2% per meter.

**Available Lengths:** 3m, 5m, 7m, and 10m

## 4 HUMIDITY & AMBIENT TEMPERATURE SENSOR

The IntelliSAW Humidity Sensor provides real-time, continuous monitoring of relative humidity and ambient temperature to identify the potential for flashover. The sensor's sintered cap, threaded body, water resistant M12 connector, and 4kV surge protection provides the level of packaging robustness required for reliable operation in harsh environments. The IntelliSAW CAM™ platform allows up to 8 humidity sensors to be bussed together for multiple location installations such as along a bus duct.



### 4.1 SPECIFICATIONS

#### Humidity Measurements

Range	0 to 100% Relative Humidity (%RH)
Resolution	± 0.1%RH
Accuracy	
Standard Range (20 to 80%RH)	± 4.5%RH
Full Range	± 7.5%RH
Repeatability	± 0.2%RH
Long term drift	< 0.5%RH/yr

#### Ambient Temperature Measurements

Range	-25°C to +120°C
Resolution	± 0.1°C
Accuracy	± 2.5°C
Repeatability	± 0.2°C
Long term drift	< 0.1°C/yr

#### Physical

Material	304 Stainless steel
Sintered Cap Material	Nickel plated bronze
Weight	0.1 kg (3.5 oz)
International Protection (IEC 60529)	Connector Side (IP 67), Cap side (IP 50)
Dielectric Strength	4 kV
Dimensions	28 W x 28 H x 80 mm D

#### Mounting

Body thread	M22 x 1.5 thread (nut included)
Body	24 mm hex body
Connector	M12, 4-pole socket



## 4.2 DIMENSIONS

The humidity sensor has dimensions of 28 W × 80 H × 28 mm D.

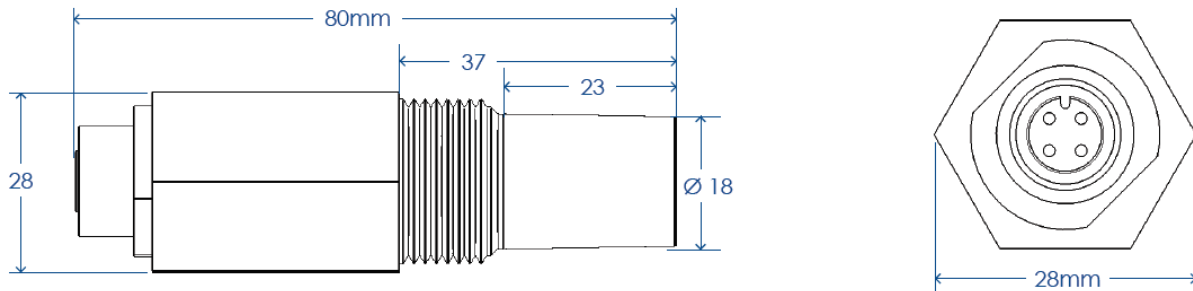

Figure 9: Humidity Sensor Dimensions

## 4.3 LABEL

The humidity sensor has one label, containing the model number and serial number.

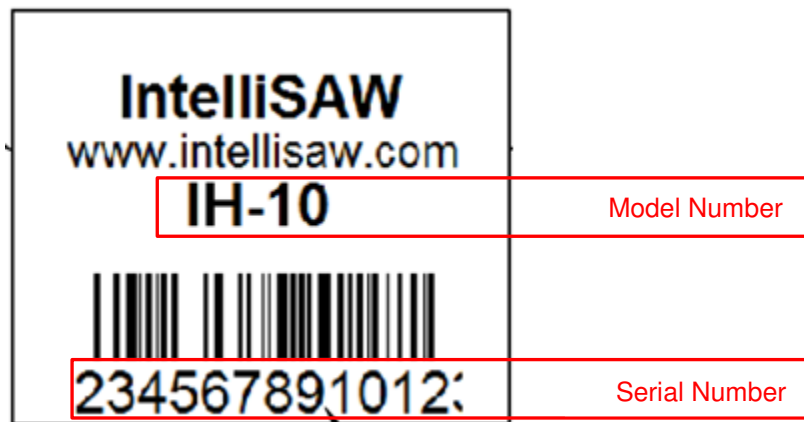

Figure 10: Humidity Sensor Label

## 4.4 MOUNTING OPTIONS

**Panel Mount:** The sensor body can be inserted into a 22.5mm punch out and fastened with a M22 x 1.5 thin hex nut.

**Bracket Mount:** The sensor can be connected to a 90° bracket with the thin hex nut for alternative mounting methods. Bracket size: 44.5 W x 38 H x 38mm L

Note that the humidity sensor's sintered cap should be pointed downward or at least be horizontal to prevent collection of condensation inside the sensor.

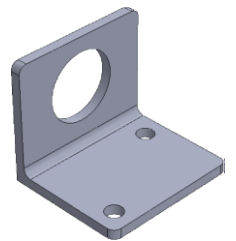

## 4.5 WIRING

The Humidity sensor can be wired in multiple configurations. The components are as follows

ID#	Description	Manufacturer	Part #
1	<b>Humidity Sensor (Panel or Bracket Mount)</b>	<b>IntelliSAW</b>	Panel: IH-10 Bracket: IH-BR-10
2	M12 Plug connector <b>(Connector to Humidity sensor or M12-T)</b>	Omron	XS2G-D423
3	<b>Cable, 4-conductor, shielded, 18awg</b>	N/A	N/A
4	M12 T connector	Phoenix Contact	1559783
5	TERM BLOCK PLUG 4POS STR 3.5MM <b>(Connector to CAM-4 or Reader)</b>	On Shore Technology	OSTTJ0411530

### 4.5.1 Single Connection

IntelliSAW Humidity Sensors communicate with low power I2C communications. 4 conductor shielded cable is used for communications between the humidity sensor and a monitoring unit. IntelliSAW offers standard cable lengths for one-to-one connections.

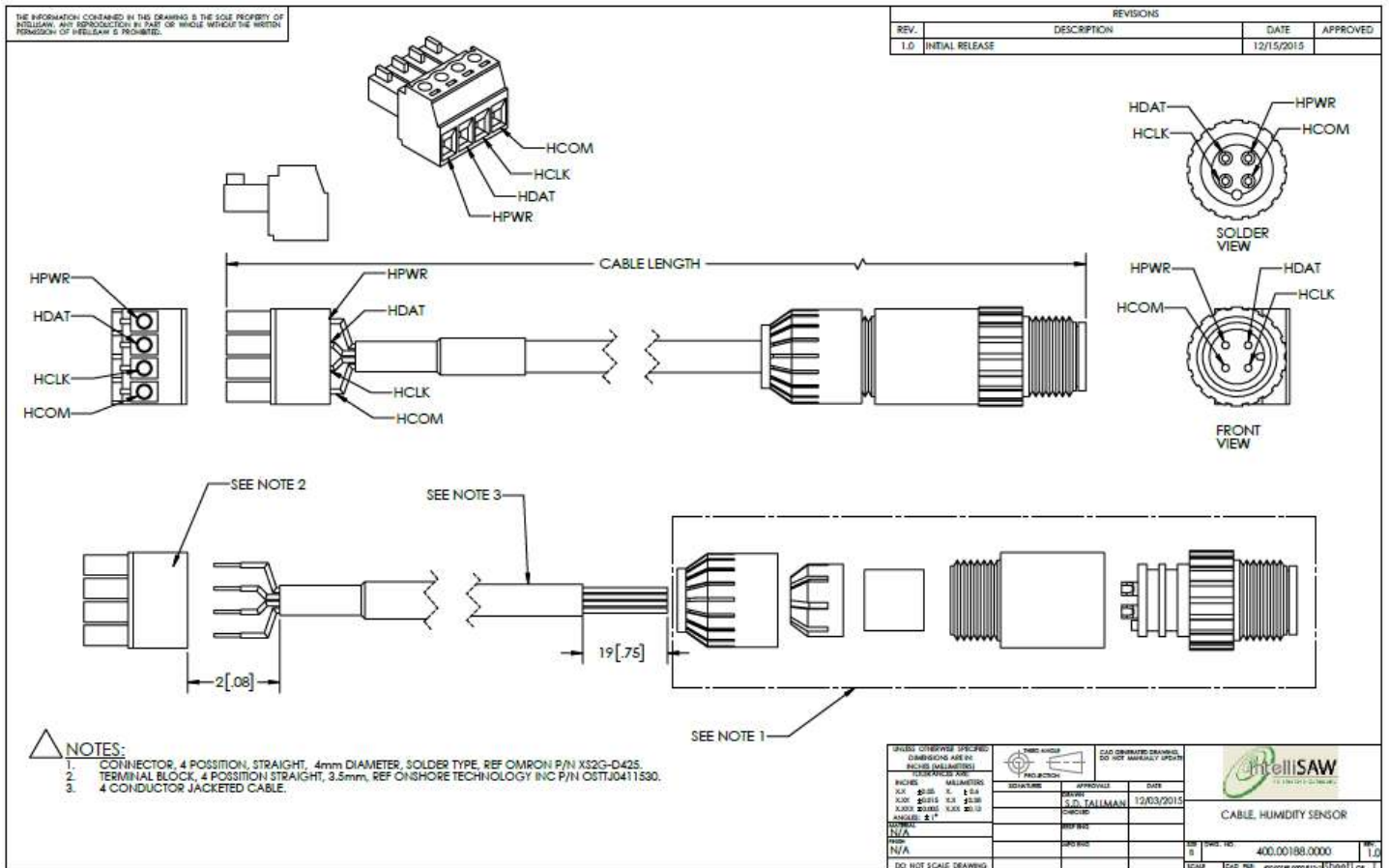

Figure 11: Standard wiring from Humidity Sensor to Monitoring Unit

### 4.5.2 Series Connect

Humidity sensors can be series connected, with the last sensor capable of being up to 100m away. Standard M12 T-connectors and humidity interface connectors are needed.

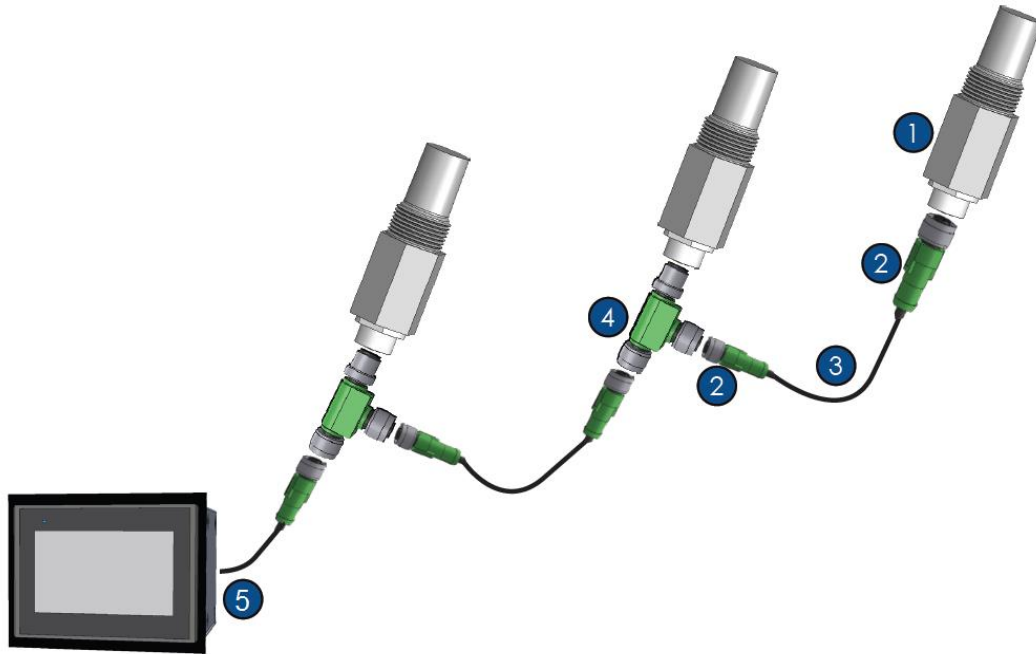

Figure 12: Series Connected Humidity Sensors

### 4.5.3 Star Connect

Although the Humidity Sensors can be star connected, it is not recommended as it goes against the standards of serial connections, creating signal reflections. The Maximum cable length for a star connection should be 15m. Standard M12 T-connectors and humidity interface connectors are needed. The wires should be grouped by color in a terminal block.

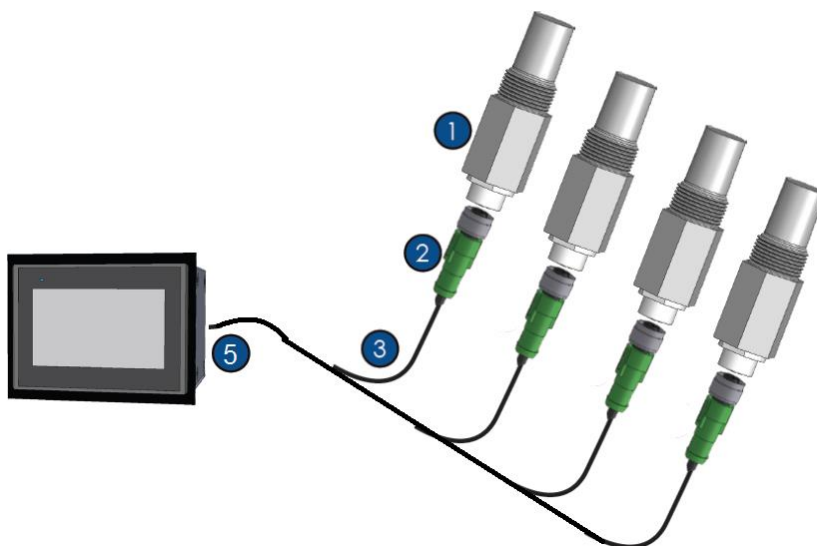

Figure 13: Humidity Star Connection

## 5 INSTALLATION



### WARNING

**INSTALLATION ASSUMES THE ASSET IS DE-ENERGIZED AND PROPERLY GROUNDED TO ASSURE A SAFE INSTALLATION. PROPER LOCK-OUT TAG-OUT PROCESSES SHOULD BE FOLLOWED BASED ON CUSTOMER REGULATIONS.**

**Failure to follow the instructions given can result in death or serious injury**



### WARNING

**PROFESSIONAL INSTALLATION REQUIRED.**

INSTALLATION AND CONFIGURATION SHOULD BE PERFORMED ONLY BY PERSONNEL WHO ARE TECHNICALLY COMPETENT AND AUTHORIZED TO DO SO. LOCAL REGULATIONS REGARDING ELECTRICAL INSTALLATION AND SAFETY MUST BE OBSERVED.

**Failure to follow the instructions given can result in death or serious injury**

### 5.1.1 Typical Installation

The following are examples of where sensors and monitoring units could be located within a medium voltage switchgear vertical section.

**Depending on the asset manufacturer or type of install (retrofit vs. new hardware), all sensor locations may not be possible on system retrofits.**

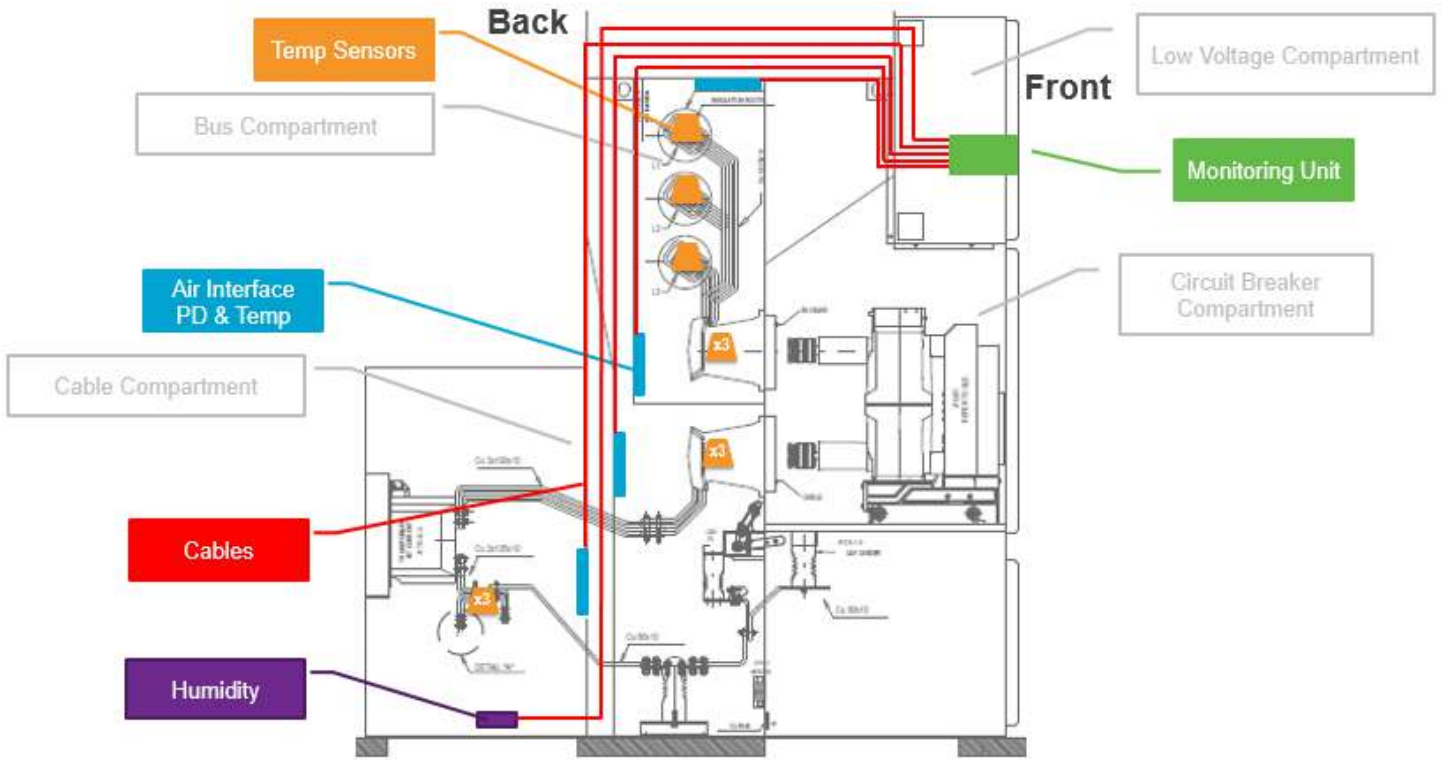

Figure 14: IEC style Medium Voltage Switchgear

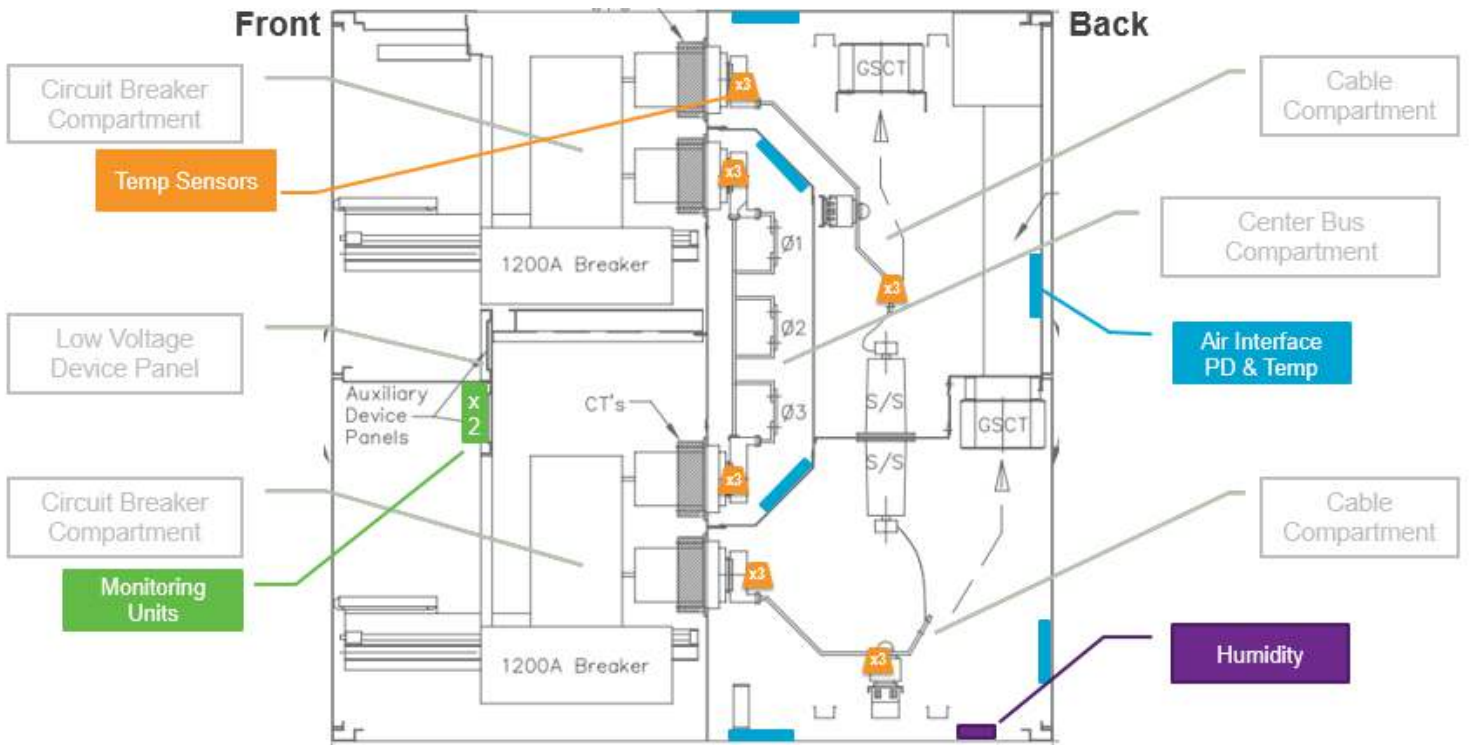

Figure 15: ANSI Style Medium Voltage Switchgear

## 5.2 TEMPERATURE SENSOR / AIR INTERFACE INSTALLATION

### IMPORTANT

Temperature sensors must be installed using the ***IntelliSAW Configuration Tool*** while the asset is de-energized. Failure to do so may result in low sensor-to-air interface signal strength and poor operations.

### 5.2.1 Required Hardware

Temperature sensor installation requires the use of the following hardware:

- **IntelliSAW**
  - Monitoring unit: Reader or CAM-4
  - CAM Air Interface with cable
  - Configuration Tool (software)
  - USB A to mini cable
- Laptop
- Temperature measurement reference (i.e. RTD or Thermocouple)
- Mechanical
  - Torque wrenches
  - Alternative mounting hardware

### 5.2.2 Basic Insulation Level (BIL)

Insulation levels are designed to withstand surge voltages, rather than only normal operating voltages. The system must operate below a Basic Insulation Level (BIL) to withstand these surges.

With respect to IntelliSAW components, this means specific spacing requirements need to be maintained when installing air interfaces, cables, temperature sensors, humidity sensors, or any other non-earthed conductors. The table below is a recommended IEC spacing guidelines (ANSI are similar):

Equip. Class	Operating Voltages	Withstand Voltage	BIL	Air Gap (no test)
7.2kV	3.3 - 6.6kV	20kV	60kV	100 mm
12kV	10 - 11kV	28kV	75kV	120 mm
17.5kV	13.8 - 15kV	38kV	95kV	160 mm
24kV	20 - 22kV	50kV	125kV	220 mm
36kV	25.8 - 36kV	70kV	170kV	320 mm

### 5.2.3 RF Isolation and Maximum Sensor Count

Each IntelliSAW monitoring unit supports up to 12 unique wireless temperature sensors operating in dedicated frequency bands (IS01, IS02, etc.). Typical application environments will require more than one antenna to interrogate the 12 sensors. If a reader interrogates two sensors of the same frequency band, it will be unable to distinguish between the data from either sensor. This means that two sensors having the same frequency band **MUST NOT** be installed in the same compartment for interrogation by an air interface.

Before installation, determine the system configuration based on the required measurement locations and RF isolation.

- If there is poor RF isolation between compartments or between adjacent cubicles, care must be taken when placing temperature sensors. Most often, a 6 sensors configuration will be used.
- If there is acceptable RF isolation between compartments and adjacent cubicles, up to 12 sensor can be installed in a cubicle.
- Although proper isolation may be available, installation may be limited due to the access to asset compartments or the BIL cannot be maintained.

### 5.2.4 Sensor Arrangements

Sensors should be installed in compartments based on their 3-phase sensor groupings as described in section 2.4 [Grouping](#). If there is RF leakage between cubicles (as is often found in the bus bar compartment of switchgear), sensors in an adjacent cubicle could be interrogated by the air interface, resulting in two sensors of the same frequency band being read. **This problem is relatively easily solved with the proper arrangement of sensors in each cubicle.**

Note the sensor locations need to coincide with the placement of the air interfaces for optimal signal strength. The configurations below show examples of sensors positioning and final frequency band considerations.

Based on RF Return loss, the Sensors to Air interface locations should follow the following scheme:

- **Closest to Air interface:** Sensor # 1, 2, 11,12
- **Intermediate:** Sensor # 3, 4, 9, 10
- **Farthest:** Sensor # 5, 6, 7, 8

Sensor numbers should not be repeated in adjacent compartments, represented by blue circles in the image below.

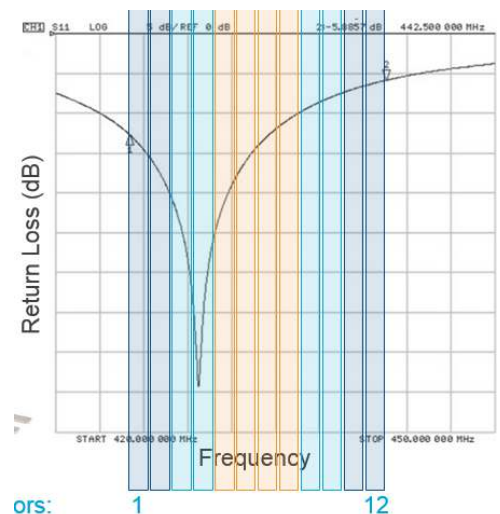

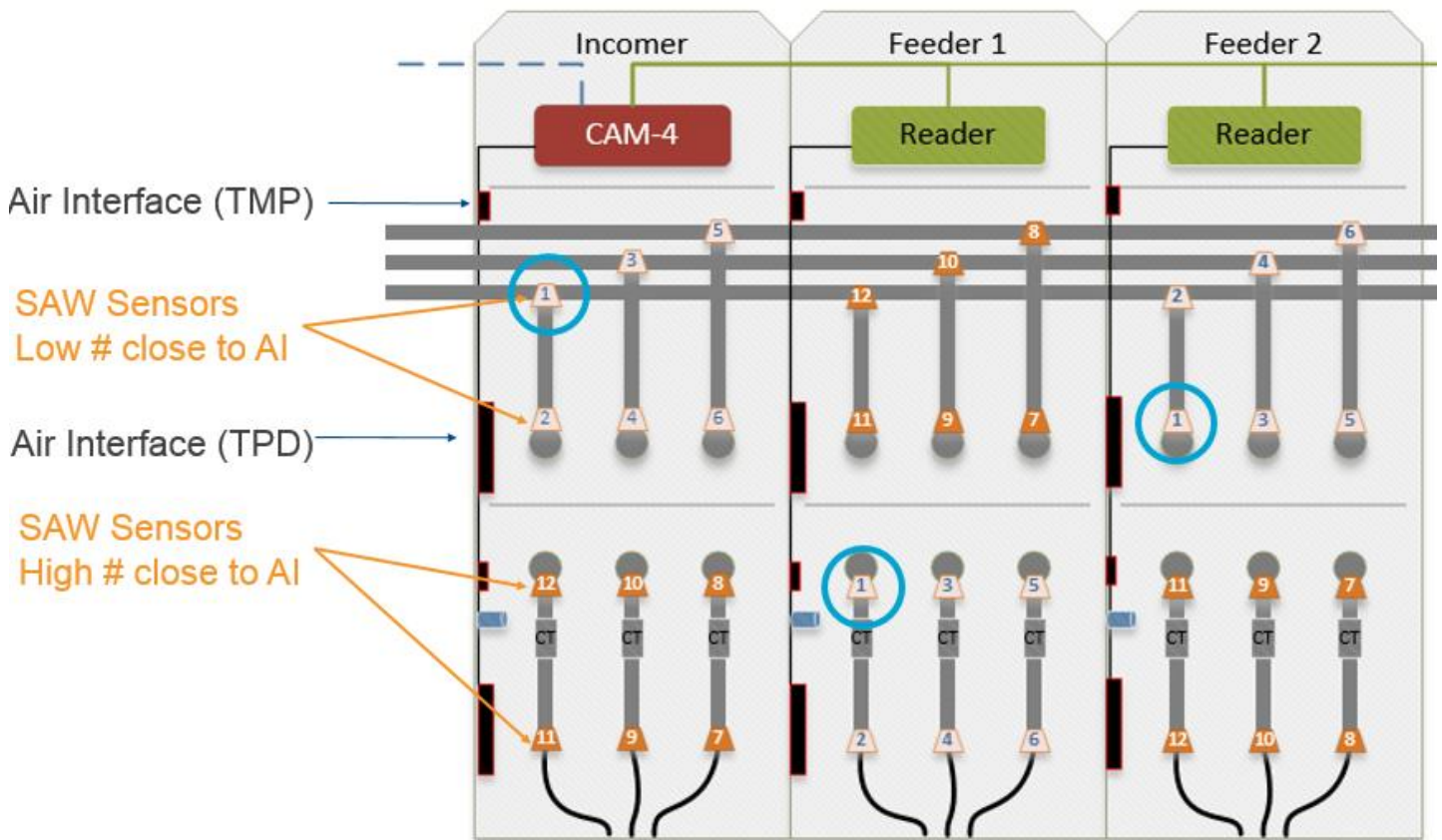

Figure 16: Example Sensor Configuration

### 5.2.5 Mounting Temperature Sensors

The SAW temperature sensors can be bolt mounted, tie wrapped with high temperature grade tie wraps, taped with high temperature grade tape or heat shrink. The Temperature sensors can also be installed under insulation boots or insulation tape.



Figure 17: Example Temperature Sensor under Insulation Boots



Temperature sensors must make direct contact with the bus or line they are monitoring. Always use the manufacturer's recommended torque ratings.

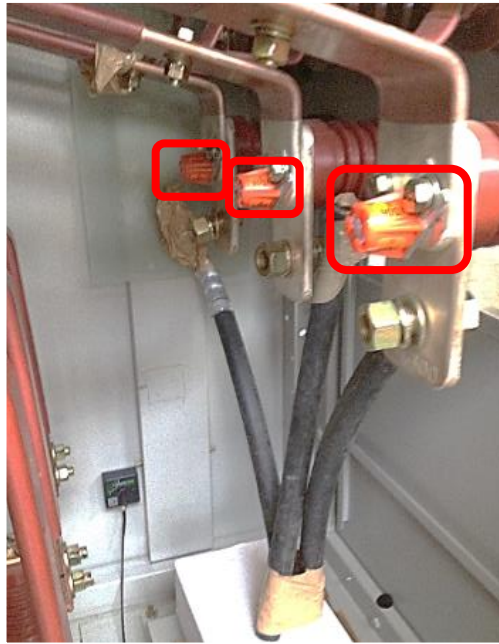

Figure 18: Example Temp Sensor Install



#### **WARNING**

**ALL BIL LEVELS MUST BE MAINTAINED WHEN INSTALLING THE TEMPERATURE SENSORS. THE HEIGHT OF THE SENSORS MUST BE TAKEN ACCOUNT WHEN DETERMINING BIL LEVEL.**

**Failure to follow the instructions given can result in death or serious injury**

### **5.2.6 Radiation Patterns**

The SAW temperature Sensor and Air interfaces have unique radiation patterns and rely on an RF reference plane (metal surface) to complete the RF circuit.

#### **5.2.6.1 SAW Sensor**

The SAW Temperature Sensor uses a monopole antenna and has a radiation pattern similar to the image below:

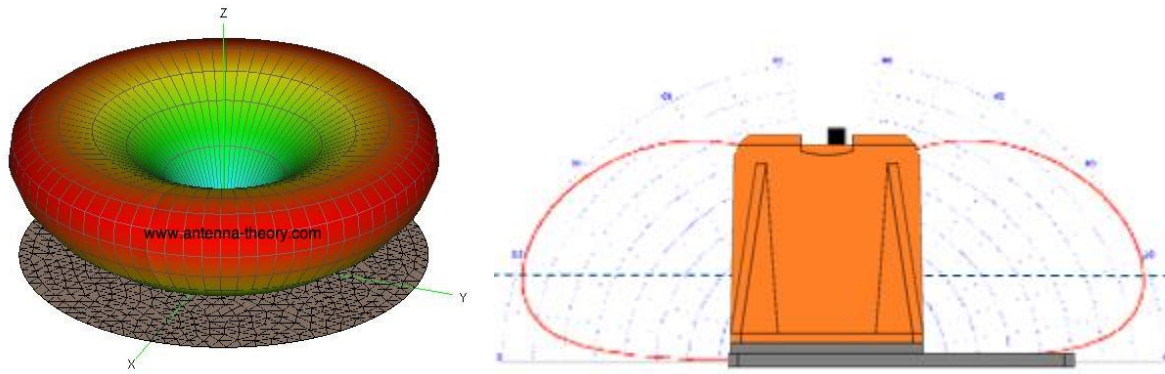

Figure 19: (Left) Monopole Radiation Pattern. (Right) Pattern Relative to sensor

### 5.2.6.2 Air Interface

The air interfaces are Planar Inverted-F Antennas (PIFA) and have RF emission / radiation patterns similar to the image below. This is important to realize when placing an air interface to successfully interrogate a temperature sensor.

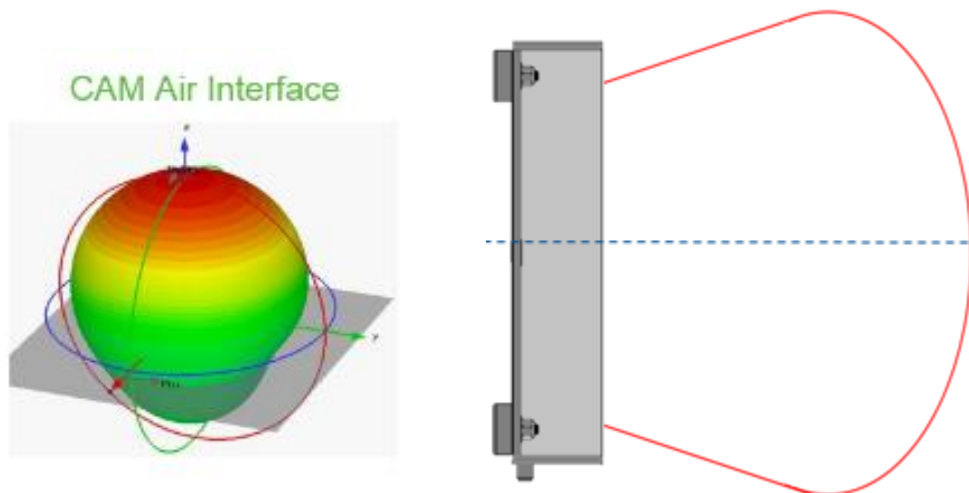

Figure 20: (Left) Air Interface Radiation Pattern. (Right) Pattern Relative to Air Interface

#### NOTICE

The monitoring unit output power is transmitted through the Air Interfaces and is regulated by the FCC. The FCC regulations require the antenna to be installed in metal enclosed compartments similar to the build of a Medium Voltage Switchgear. **Using the temperature sensors / air interface in any other capacity will result in diminished signal strength and potential violation of the FCC regulations.**

**Failure to follow these instructions can result in property damage.**

### 5.2.6.3 Air Interface and Nearby Metals

Note, nearby metal and structures within the asset will affect the radiation patterns and operating frequencies of the air interfaces. It is advised to keep the air interface at a minimum of 100mm away from metal other than the surface on which it is mounted.



Figure 21: Keep Air Interface away from nearby metals

### 5.2.6.4 Metal Obstructions

The radiation pattern from an air interface propagates through space until it impinges on something else. If the object is metallic and has sufficient size, the propagating wave reflects off the metallic surface and can cause destructive interference.

**Since the IntelliSAW temperature sensors need to be located at specific points where temperatures need to be measured, these locations cannot be altered. The only freedom an installer has is to select an air interface location that minimizes any cancellation due to nearby metal structures.**

### 5.2.6.5 Sensor to Air Interface Positioning

Optimal position between an air interface and SAW temperature sensor will be determined through monitoring the signal strength using the [IntelliSAW Configuration Tool](#). General rules can be applied when positioning the air interface:

**Optimal position** (based on radiation patterns): In this way, the strongest field strengths for each structure are aligned and can help to ensure very good signal levels.

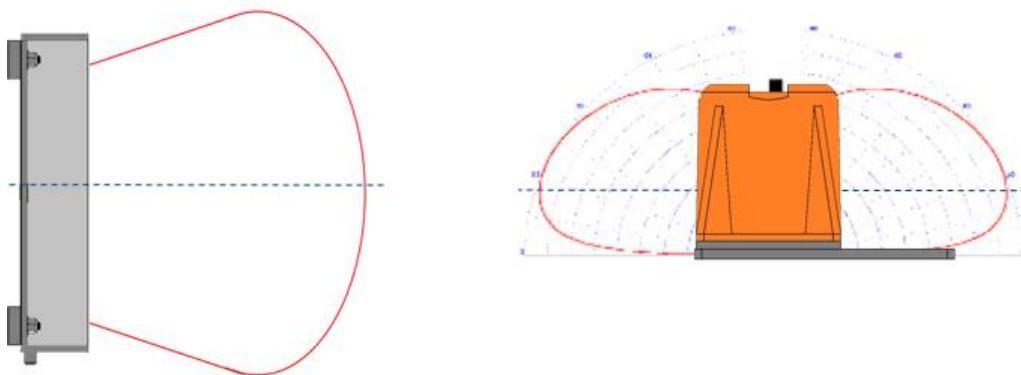

Figure 22: Optimal Air Interface to Sensor Positioning

**Intermediate Position.** In this case, to prevent excessive loss due to lowered field intensity, try to keep the angle between the ground planes and the center of the structures at  $45^\circ$  or less.

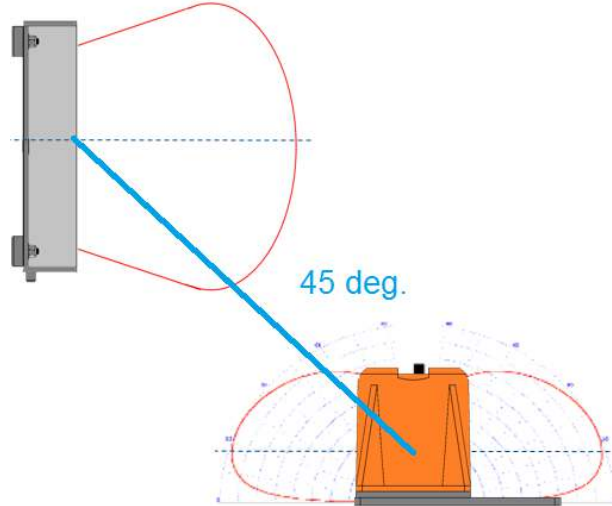

Figure 23: Air Interface to Sensors can use angles to ensure proper signal strength

**Least Optimal:** In this case, the structures are aligned so that the SAW Sensor's zone of weakest field strength is facing the Air Interface. A significant reduction in received signal levels can be expected of an air interface aligned in this manner.

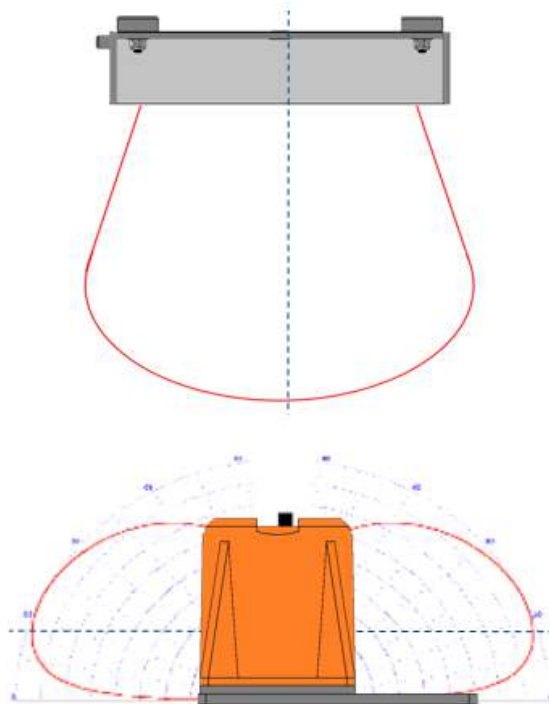

Figure 24: Least Optimal Positioning

## 5.2.7 Air Interface Installation

The Air Interfaces are used to interrogate the SAW temperature sensors. The TPD air interface can also monitor PD emissions. Both the TMP (temp only) and TPD are installed the same way.



### WARNING

**ALL BIL LEVELS MUST BE MAINTAINED WHEN INSTALLING THE AIR INTERFACES..**

**Failure to follow the instructions given can result in death or serious injury**

### 5.2.7.1 Air Interface Wiring

The Air Interface connects to a monitoring unit through shielded RF cable. When wiring the antenna to a monitoring unit, necessary BIL levels must be maintained during routing of the cable. Air Interface cabling come in standard lengths; cross sections of assets should be used to determine the best distance to minimize extra cable. Wiring shall be completely contained within the asset metal housing, or metal conduit shall be used to protect the cabling. RF cables should not be routed in proximity to MV or HV cables. Even shielded MV and HV cables carry substantial shield currents and voltages. Routing RF cables within the BIL separation of unshielded MV and HV cables can cause partial discharge in the cables and can induce life threatening voltages on ungrounded RF cables.



### WARNING

**EXTRA CABLE SHALL NOT BE BUNDLED IN HIGH VOLTAGE COMPARTMENTS.**

**Failure to follow the instructions given can result in death or serious injury**

### 5.2.7.2 Air interface Mounting

Use the magnetic mounts to preliminary locate the air interfaces and to optimize location to ensure proper signal strength. The air interface can be left secured by the magnets or alternatively may be bolt mounted once final location is indicated. **Use a permanent marker to identify location.**

## 5.2.8 Optimizing Signal Strength & Configuring the System

Once the sensors, antennas and readers have been preliminary installed in the cubicle, use the IntelliSAW software tools to configure the system. A computer with **IntelliSAW Configuration Tool** and a proper USB interface cable are required. **Please refer to the following document to configure a monitoring unit: (910.00160.0001) IntelliSAW Configuration Tool User Manual** and **Commission Temperature Sensors.**

### 5.2.8.1 Ensure Final Asset Assembly

The SAW Sensors and Air Interface rely on adequate RF signals for reliable readings. It is recommended to have asset as close to final assembly as possible - all of the sheet metal panels must be in place, breakers racked in, and all cubicle compartment doors must be closed. Only in this condition will the sensor readings provided by the reader be valid, representing how the temperature monitoring system will behave in actual use.

In the example, the cover shown to the left of the opening was used to close up the remaining open area of the switchgear before taking measurements.



**If the asset is partially assembled, the final signal strength may change and impact readings.**

### 5.2.9 SAW Temperature Calibration

To finalize the installation, the SAW Temperature Sensors must be calibrated through the ***IntelliSAW Configuration Tool*** – this again assumes the asset is a complete assembly. Sensor Calibration occurs after signal strength between the Air Interface and SAW Sensors has been optimized and verified.

#### 5.2.9.1 Calibration Reference

A reference measurement from a third party sensor is required for final calibration.



### 5.3 PARTIAL DISCHARGE CONFIGURATION

If the system being installed includes SAW temperature sensors, the TPD Air Interface used for Partial Discharge monitoring should first be setup and configured for optimal SAW sensor locations. Once completed, the PD monitoring frequency configuration can be completed.

If the system is not being installed with SAW temperature sensors and is only being used as a PD solution, the Air Interface should be installed to ensure proper BIL is maintained. The location is not critical for PD only application, provided the air interface has a direct view into the enclosure, as emissions will occur within the enclosure and multiple reflections will bring the signal to the air interface.

Please refer to the following document to configure PD in a monitoring unit **Please refer to the following document to configure a monitoring unit: (910.00160.0001) IntelliSAW Configuration Tool User Manual and **Commission Partial Discharge.****

### 5.4 HUMIDITY / AMBIENT SENSOR INSTALLATION

The IntelliSAW humidity sensor is a pre-calibrated humidity and ambient temperature sensor with Sensirion CMOSens® technology.

- Each humidity sensor is individually calibrated in a precision humidity chamber. The calibration coefficients are programmed into an OTP memory on the chip. These coefficients are used to internally calibrate the signals from the sensors.
- The capacitive humidity sensors provide digital and fully calibrated output that allows for easy integration without the need for additional calibration.

#### 5.4.1 Mounting

The Humidity Sensor uses an M22 x 1.5 body thread and comes with M22 x 1.5 nut. This allows for mounting into a compartment through a hole or a tapped hole. The sensor can also be ordered with a bracket for mounting on internal surfaces. Sensors could also be tie wrapped.

While condensation should not occur in electrical assets, the sensor should be installed with the sensing end slightly downward to prevent collection of water in the sensor body.

#### 5.4.2 Humidity Sensor Wiring

Complete the sensor wiring based on the type: one-to-one, series, or star. Wiring shall be completely contained within the asset metal housing, or metal conduit shall be used to protect the cabling.

## 5.5 OUTDOOR ASSET INSTALLATION WITH ENVIRONMENTAL ENCLOSURES

When installing into outdoor assets such as ISO Phase bus ducts or transformer connector boxes, and an environmental enclosure is required for the reader and for the humidity sensor / air interface connections. All cabling shall be installed in metal electrical conduit.

As noted in the image below:

1. **IntelliSAW Control environmental enclosure:** Designed for Power Environments, the enclosure is a NEMA 4X with an IntelliSAW IRM-48 Reader, Thermostat / Heater, Power Supply, Circuit Breaker, and Surge Suppression. Note conduit connections for air interface and humidity cabling. Multiple types of enclosures are available depending on number of CAM-4 or Readers.
2. **IntelliSAW Humidity & Air Interface environmental enclosure:** Designed to house a humidity sensor and/or a lightning arrester for air interface connectors. Multiple types of enclosures are available for single asset or three phase ISO for daisy chaining connections.
3. **Conduit:** Direct connect conduit can be used to house air interface cables.

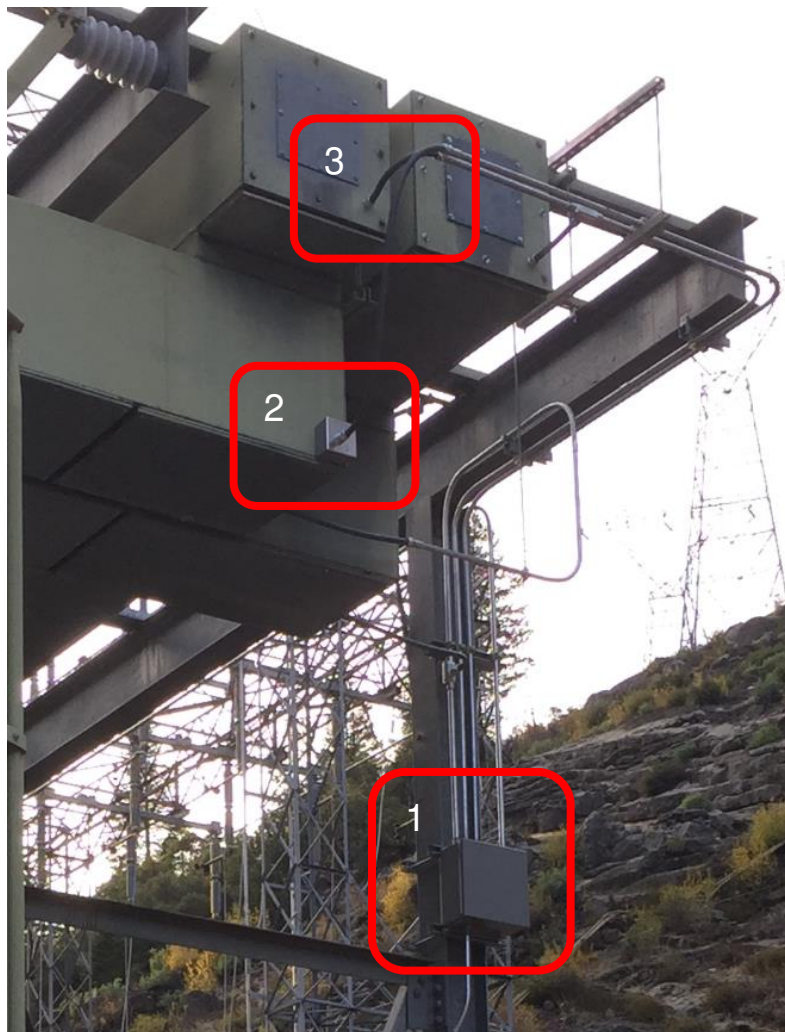

Figure 25: Outdoor installation



## CONTACT

---

### Head Office:

**IntelliSAW – ALTANOVA GROUP**

100 Burt Rd.

Andover, MA 01810

[contact@intellisaw.com](mailto:contact@intellisaw.com)

+1-978-409-1534

[www.altanova-group.com](http://www.altanova-group.com)

### Regional Office:

**IntelliSAW LATAM**

**IntelliSAW China**

### Regional Distributors:

Visit [www.altanova-group.com](http://www.altanova-group.com) for the latest distribution locations.