TABLE OF CONTENTS

SPECIFICATIONS	1
1 GENERAL	7
2 APPLICABLE STANDARDS	15
3 CHARACTERISTICS	16
3.1 FOREWORD	16
3.2 HV GENERATION.....	16
3.2.1 <i>Output frequency</i>	16
3.2.2 <i>Other features of main outputs</i>	16
3.3 MEASURES ACCURACY.....	17
3.3.1 <i>Applicable test set</i>	19
3.4 DISPLAY.....	20
3.5 TEST CONTROL.....	20
3.6 TEST SAVING.....	20
3.7 MENU SELECTIONS	21
3.8 STANDARD CONNECTION CABLES (PII66175)	26
3.9 OTHER CHARACTERISTICS	27
4 OPTIONS	28
4.1 TRANSPORT CASES (CODE PII67175, PII66175)	28
4.2 PADS LICENCE (CODE PII10176T).....	29
4.3 REMOTE SAFETY SWITCH (CODE PII42175)	29
4.4 WARNING STROBE LIGHT (CODE PII43175).....	30
4.5 RCTD REACTOR FOR MOTORS AND GENERATORS MEASURES (CODE PII47175).....	30
4.6 CAP-CAL REFERENCE CAPACITOR (CODE PII40175).....	31
4.7 STOIL CELL FOR THE INSULATING OIL CHECK (CODE PII13175)	33
4.8 DIGITAL THERMO HYGROMETER (CODE PII44175)	33
4.9 RTD CAPACITANCE FOR TRANSFORMER RATIO AT HIGH VOLTAGE (CODE PII41185)	34
4.10 HOOK FOR HV CONNECTION (CODE PII42185)	34
4.11 IN-A AND IN-B CURRENT MEASURE INPUTS UP TO 10A (CODE PII50185).....	34
5 PROTECTIONS	35

Page left intentionally blank.

Disclaimer

Every effort has been made to make this material complete, accurate, and up-to-date. In addition, changes are periodically added to the information herein; these changes will be incorporated into new editions of the publication.

ISA reserves the right to make improvements and/or changes in the product(s) and/or the program(s), described in this document without notice, and shall not be responsible for any damages, including but not limited to consequential damages, caused by reliance on the material presented, including but not limited to typographical errors.

Copies, reprints or other reproductions of the content or of parts of this publication shall only be permitted with ISA prior written consent.

All trademarks are the property of their respective holders.

Copyright 2020© ISA S.r.l. Italy - All rights reserve

Page left intentionally blank.

1 GENERAL

The portable, high accuracy test sets allows performing $\tan(\delta)$, dissipation factor and capacitance tests on CT, VT, PT, CB, motors and generators. The TDx 5000 is developed to furnish a more compact solution to who is interested only on $\tan(\delta)$ test; it is the union of the measuring device and power generation in one instrument.

The TDx 5000 performs the measurement of the $\tan(\delta)$, of the dissipation factor and of the capacitance of a transformer or of a bushing, at the frequency of the mains or in a wide frequency range. The measurement is performed by the module, which is equipped with a patented measurement circuitry. It is also possible to perform the No load / Excitation current test in power transformers. The TDx 5000 can be used in all the substations, HV and EHV included.

The measurement circuitry incorporates a reference high voltage capacitor, rated 200 pF, with the following: a variation better than 0,05%/year, a temperature factor better than and 0,01%/°C, and a $\tan(\delta)$ better than 0,005%, and a reference resistor bridge, with accuracy better than 0,01% and thermal drift less than 1 ppm/°C. The patented circuitry and the variable frequency output make test results immune from external noise, even in the very highly noisy environment. The noise it is suppressed using a narrow bandwidth numerical filter. In case of a test frequency equal to the line frequency, the measurements are automatically performed at different frequencies ($F_{lin} \pm 4$ Hz).

Before each test the TDx5000 automatic check and calibrate itself with the internal reference capacitor.

The maximum interference conditions at line are the following:

- Electromagnetic: 500 μ T, at 50 and 60 Hz in any direction
- Electrostatic: 15 mA rms of the interference current into any lead or cable with no loss of measurement accuracy. Applicable to a maximum ratio of interference current to specimen current 20:1

Keyboard, dedicated keys, control knob and display can control the test set locally. Test results and settings can be saved in a PC by the software suite TDMS, which comes with the device. The optional PADS program allows also controlling the device from the PC.

The following table lists the optional modules enhance the TDx 5000 features:

Item	Option	Code	Description
1	Transport Cases	PII67175 PII66175	They allow transporting the device and cables
2	PADS license	PII10176T	PC Remote control of the test set
3	Remote Safety Switch	PII42175	When the Remote Safety Switch is connected and enabled, it avoids any current or voltage generation from pressing START/STOP button on the STS only
4	Warning Strobe Light	PII43175	It alerts when the test is performed
5	CAP-CAL	PII40175	Purpose of the reference capacitor is to check the actual calibration of TD for the measures of the capacitance and $\tan(\delta)$
6	STOIL	PII13175	The oil cell is for $\tan(\delta)$ measurement of PT oil
7	Digital thermo hygrometer	PII44175	The option allows measuring ambient temperature and humidity, and to input them into the test settings, if it is necessary
8	RCTD	PII47175	Compensation Inductor for high current $\tan(\delta)$ test on motors and generators
9	RTD	PII41185	Capacitance for transformer ratio at high voltage

Table 1- Optional modules

The basic TDx 5000 function is to generate voltages to test the quality of insulation; only one test at a time. The test is selected on the LCD screen by means of the multi-function knob. Test results are kept in local memory or in a USB card, and can be transferred to a PC later, along with settings.

The capacitance and $\tan(\delta)$ measurements can be performed on CTs, VTs, CBs, PTs and bushings.

TDx 5000 contains a generator, with an output of 12kV 100mA steady at network frequency (50 or 60Hz).

In local control mode, the output is adjustable and metered on the large, graphic LCD display. With the control knob and the LCD display it is possible to enter the MENU mode, which allows setting many functions: this makes TDx5000 a very powerful testing device, with manual and automatic testing capabilities, and with the possibility to transfer test results to a PC via USB, ETHERNET or Pen Drive.

In the results reports are included the following informations:

- Place, substation name, line, phase, model, serial number, operator, date and time
- Nominal values: type of device, power, primary and secondary voltage or current
- Parameters tolerances
- For PT's: nominal tap voltages
- Test result table with assessments, graphs and environmental parameters etc.
- Notes and comments

In the PC control mode, the PADS program allows performing the same tests as in the local mode, with the same control windows. It allows also downloading, displaying and analyzing test results obtained in local mode.

PADS operates with all WINDOWS versions.

The ease of operation has been the first goal of TDx 5000: this is why the LCD is graphic, and so large. With it, the dialogue in menu mode is made easy.

On the TDx 5000 it is available a digital input, used only to control the thermal state of resonating inductors.

The instrument is housed in a transportable aluminum box, which is provided with removable cover and handles for ease of transportation. An optional trolley is also available.

The following image exhibits the TDx 5000, with the protection cover lifted:



Figure 1 - TDx5000

The following image exhibits the front panel:

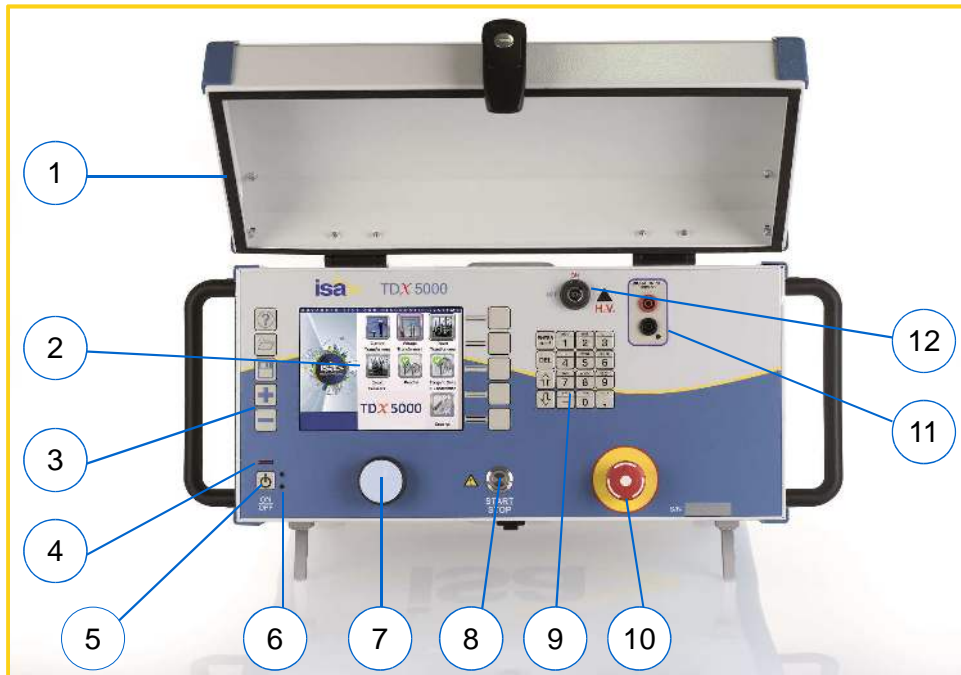

Figure 2 - Test set front panel

The following table lists all the elements of the front panel:





ITEM	Component		
1	Cover		
2	Display		
3	Pushbuttons		Help. Pressing it, the screen displays the information related to the test to be performed showing the connection scheme between TDx5000 and the device under test
			Open file. It allows to access the list of saved test results (the list can be located in the internal memory or on the USB key)
			Save file. It allows saving the test result. Pressing it, it is possible to access the list of saved test results (the list can be located in the internal memory or on the USB key)
			Increment and decrement buttons. To input a value, select the field, and then: <ul style="list-style-type: none"> Edit the desired value, via the keypad Increment or decrement the value, pressing the above pushbuttons Rotate the knob clockwise (increment) or anti-clockwise (decrement) Press the keyboard up key to increment, and the keyboard down key to decrement The amount of the increment or decrement is: ten units, for the plus and minus keys; one unit, for the knob, and one tenth, for the up-down arrows
4	Power-on light: it is ON when the test set is operating		
5	Power ON and OFF push-button		
6	Mains lights: they turn on very shortly as the test set is connected to the mains		
7	MENU control knob, with switch		
8	Test START and STOP push-button		

Table 2 - Frontal panel components (1/2)

ITEM	Component	
9	Function keys	 <ul style="list-style-type: none"> • The twelve buttons to the right behave as a portable phone • ENTER confirms what is edited • DEL <ul style="list-style-type: none"> ○ If the field is numeric, it deletes the first digit to the left. It is not possible to select the digit to delete: as the wheel is touched, the digit changes ○ If the field is alphabetic, it is possible to use the knob to reach for the letter to be deleted: the deleted letter is the one to the left with respect to the cursor. If the cursor is completely to the left, DEL deletes the letter to the right • As explained above the arrows, when the context is numeric, increment or decrement the value; in a selection page, they allow to move around
10	Emergency push-button with lock-in	
11	Digital input sockets. The LED turns ON when the input is closed or with voltage	
12	Enable key, for HV tests	

Table 2 – Frontal panel components (2/2)

The following image exhibits the side panel on the left:

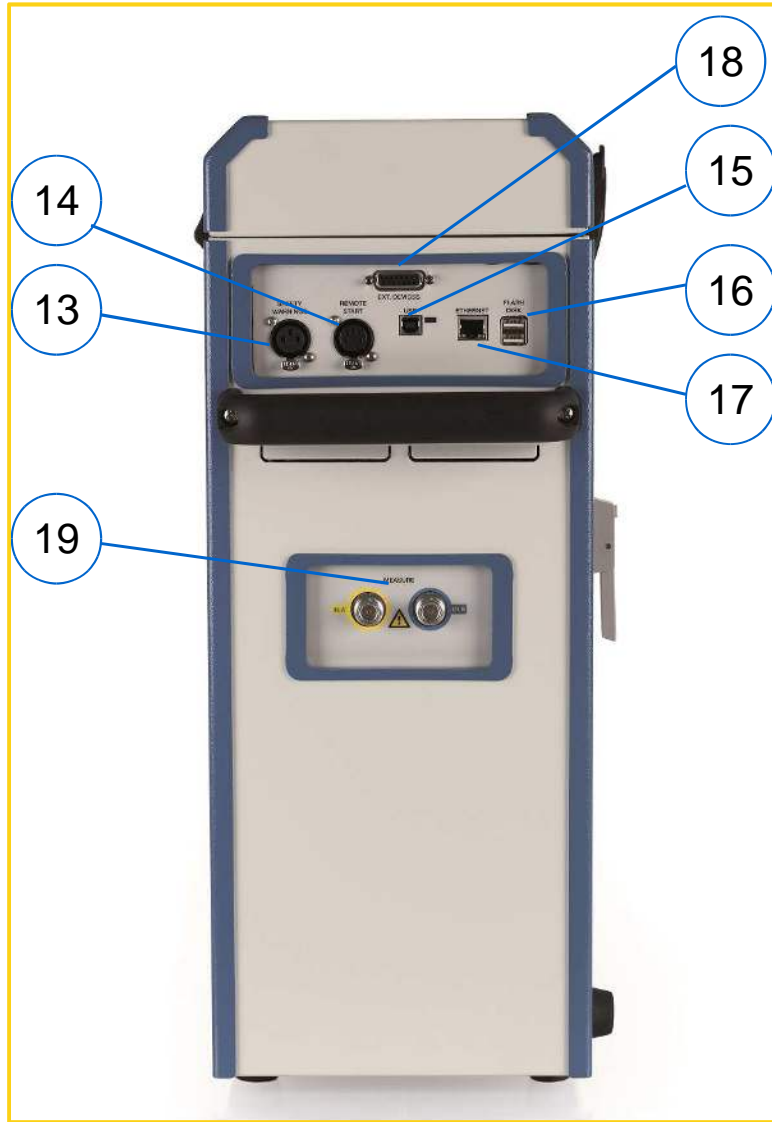

Figure 3 – Left panel components

The following table lists the elements of the left panel:

ITEM	Component
13	Alarm output connector, for the light strobe with buzzer option PII43175
14	Remote start input connector, for the remote push-button option PII42175
15	USB connection only for ISA diagnostic
16	Flash disk connector for the local test results saving or for moving the local test results from the local memory
17	ETHERNET connection to the PC. It incorporates two lights which turn on when the test set is connected
18	Communication Connector
19	UST-A and UST-B input connectors

Table 3 – Left panel components

The following image exhibits the side panel on the right:



Figure 4 - Right panel components

The following table lists the elements of the right panel:

ITEM	Component
20	Ground connection socket
21	Resettable power supply automatic fuses, rated 16 A 240 V
22	Power supply plug

Table 4 – Right panel components

The following image exhibits the side panel on the rear:



Figure 5 -Rear panel

The following table lists the elements of the upper panel:

ITEM	Component
23	Safety ground connection for HV cable
24	High Voltage connector

Table 5 – Right panel components

2 APPLICABLE STANDARDS

The test set conforms to the EEC directives regarding Electromagnetic Compatibility and Low Voltage instruments.

The following table lists the standards related to the EMC Directive, 2014/30/UE:

Standard	Title	Requirement
EN 61326-1	Electrical equipment for measurement, control and laboratory use. EMC requirements. General requirements	
IEC EN 61000-3-2:	Electromagnetic compatibility (EMC) - Part 3-2: Limits - Limits for harmonic current emissions (equipment input current \leq 16 A per phase)	Harmonic content of power supply Acceptable limits: basic
IEC 61000-3-3	Electromagnetic compatibility (EMC) - Part 3-3: Limits - Limitation of voltage changes, voltage fluctuations and flicker in public low-voltage supply systems, for equipment with rated current \leq 16 A per phase and not subject to conditional connection	Limitation of voltage fluctuations and flicker Acceptable limits: basic
CISPR 16-1	Specification for radio disturbance and immunity measurement apparatus and methods	Acceptable limits for conducted emission: <ul style="list-style-type: none"> 0.15÷0.5 MHz: 79 dB pk; 66 dB avg 0.5÷5 MHz: 73 dB pk; 60 dB avg 5÷30 MHz: 73 dB pk; 60 dB avg Acceptable limits for radiated emission: <ul style="list-style-type: none"> 30÷230 MHz: 40 dB (30 m) 230÷1000 MHz: 47 dB (30 m)
IEC EN 61000-4-2	Electromagnetic compatibility (EMC)- Part 4-2: Testing and measurement techniques - Electrostatic discharge immunity test	Immunity tests for ESD Test values: 8 kV in air; 4 kV in contact
IEC EN 61000-4-3	Electromagnetic compatibility (EMC)- Part 4-3: Testing and measurement techniques - Radiated, radio-frequency, electromagnetic field immunity test	Immunity tests for radio frequency interference Test values (f= 900 \pm 5 MHz): field 10 V/m, modulated AM 80%; 1 kHz
IEC EN 61000-4-4	Electromagnetic compatibility (EMC) - Part 4-4: Testing and measurement techniques - Electrical fast transient/burst immunity test	Immunity tests for high speed transients (burst) Test values: 2 kV peak; 5/50 ns
IEC EN 61000-4-5	Electromagnetic compatibility (EMC) - Part 4-5: Testing and measurement techniques - Surge immunity test	Immunity tests for surge Test values: 1 kV peak differential mode; 2 kV peak common mode; 1.2/50 us
IEC EN 61000-4-6:	Electromagnetic compatibility (EMC) - Part 4-6: Testing and measurement techniques - Immunity to conducted disturbances, induced by radio-frequency fields	Immunity to low-voltage sinusoidal waveform Test values: 0.15-80 MHz, 10 Vrms, 80% AM 1 kHz
IEC EN 61000-4-8:	Electromagnetic compatibility (EMC) - Part 4-8: Testing and measurement techniques - Power frequency magnetic field immunity test	Immunity tests for low frequency magnetic fields. Test values: 30 Arms/m
IEC EN 61000-4-11	Electromagnetic compatibility (EMC) - Part 4-11: Testing and measurement techniques - Voltage dips, short interruptions and voltage variations immunity tests	Immunity test for power supply drops. Test value: 1 cycle; 100% drop

Table 6 – Standards related to the EMC Directive

The following table lists the standards related to the LV Directive, 2014/35/UE:

Standard	Title	Requirement
IEC EN 61010-1	Safety requirements for electrical equipment for measurement, control, and laboratory use - Part 1: General requirements	For a pollution degree 2: dielectric rigidity 1.4 kV AC, 1 minute The rigidity is 4600 V AC 1 minute between the high voltage output and the rest of inputs and outputs. <ul style="list-style-type: none"> Inputs/outputs protection: IP 2X, per IEC 60529, for all but high voltage outputs; IP4X for high voltage outputs Insulation resistance, at 500 V DC: > 10 MΩ Ground resistance, at 200 mA DC: < 0.1 Ω Operating temperature: (-10÷55) °C; storage: (-20÷70) °C Operating relative humidity: 0÷95%, without condensing. Storage relative humidity: 0÷96%, without condensing Altitude: less than 2,000 m
IEC 60068-2-6	Environmental testing - Part 2-6: Tests - Test Fc: Vibration (sinusoidal)	Vibration: 20 m/s ² at 10÷150 Hz
IEC 60068-2-27	Environmental testing - Part 2-27: Tests - Test Ea and guidance: Shock	Shock: 15 g; 11 ms; half-sine

Table 7 - Standards related to the LV Directive

3 CHARACTERISTICS

3.1 Foreword

TDx 5000 incorporates a generator with an output that can reach 12kV. The generator is made of an electronic type D switching amplifier, followed by a power transformer, which adapts the suitable voltage output.

3.2 HV Generation

Output adjustment is performed automatically, as a function of the selected test. For the output, the following applies:

- **Type of generator.** Electronic type D switching amplifier, followed by a high voltage power transformer, independent from the power supply
- **Output adjustable** from zero to the maximum value
- The specified **output power** is available at 25°C maximum of external temperature, and with a power supply error of 2% maximum. For higher temperatures, the maximum power decreases of 20 VA/°C
- The specified **output accuracy** and THD applies at (25±2) °C, resistive load, and burden less than 20% of the maximum, currents up to 50% of the maximum. With full temperature range, maximum current and maximum burden, errors are twice as bigger
- The specified **output characteristics** vary for frequencies below 50 Hz and above 60 Hz. Below 40 Hz there is a voltage derating on the maximum voltage allowable.

The HV generation (maximum power 3.6 kVA) has electronic control not dependent from the mains and the following table lists its main characteristics :

Maximum output voltage [V]	Output current [mA]	Maximum output duration	Frequency [Hz]
12.000	300	>240 s	1±500
	125	>1 h	
	100	steady	

Table 8 - HV generator main characteristics



ATTENTION: At 10 kV, the output (current value and duration) has the same characteristic

3.2.1 Output frequency

The following table lists the frequency range on all the AC outputs:

Frequency	1±500 Hz
Frequency resolution	10 mHz
Frequency accuracy	< 100 ppM; output voltage > 200 V

Table 9 – Frequency range on all the AC outputs

3.2.2 Other features of main outputs

The following table lists other features of main outputs:

Over-current	Alarm message
Thermal protection	For: Power supply, Power amplifier, Power transformer. The operator is alerted by a message

Table 10 – Other features of main outputs

3.3 Measures Accuracy

From previous pictures it is possible to see that there is one HV connector, and there are two metering inputs. This allows the $\tan(\delta)$ measurements of all points with one connection. Besides, the IN-A (UST-A) and IN-B (UST-B) can be used as control points to avoid the measure of parasitic capacitances.

The following table lists the voltage and current output measurement accuracy and resolution:

Internal measure	Resolution	Typical accuracy		Guaranteed accuracy	
		\pm % (rdg)	\pm % (rg)	\pm % (rdg)	\pm % (rg)
12,000 V AC	1 V	$\pm 0,2\%$	$\pm 0,5$ V	$<0,3\%$	+1 V
5 A AC (10A AC @10s model PII50185) (@ inputs A or B > 10 mA)	0.1 mA	$\pm 0,2\%$	± 1 mA	$<0,5\%$	$<0,5\%$
<10 mA AC (@ inputs A or B)	0,1 μ A	$\pm 0,2\%$	$\pm 0,1$ μ A	$<0,3\%$	+0,1 μ A

Table 11- voltage and current output measurement accuracy and resolution

The following table lists the frequency characteristics of TDx 5000:

Range	Accuracy
1÷500 Hz	50 ppM typical; 100ppM maximum

Table 12- Frequency characteristics of TD 5000

The connections of the TDx 5000 are the following:

- HV panel for the connection of the double shielded safety cable
- TDx 5000 Ground socket
- Two measurement sockets (IN A and IN B)

The available test selections are the following:

- Ungrounded: UST-A; UST-B; UST A+B
- Grounded: GST; GSTg-A; GSTg-B; GSTg-A+B

The measurements can be repeated independently from the power supply

The following table lists the derived measurements from the measurements of V and I:

Measurement	Characteristics
Capacitance	Measurement range 1, from 0 pF to 5 μ F. Resolution: 6 digits. Accuracy, typical: $\pm 0,03\%$ of the value $\pm 0,1$ pF; guaranteed: $< 0,1\%$ of the value $+1$ pF ((from 45 to 70 Hz) Measurement range 2, from 5 μ F to 200 μ F Resolution: 6 digits. Accuracy, typical: $\pm 0,1\%$ of the value ± 10 pF; guaranteed: $< 0,2\%$ of the value $+10$ pF
Tan(δ) (dissipation factor DF)	<ul style="list-style-type: none"> Measurement range 1: from 0 to 10% (capacitive). Resolution: 5 digits; accuracy, typical: 0.05% of the value ± 0.005 %; guaranteed: 0.1% of the value ± 0.005 % (from 45 to 70 Hz, current < 10 mA) Measurement range 2: from 0 to 100%. Resolution: 5 digits; accuracy, typical: 0,3% of the value $\pm 0,01$ %; guaranteed: 0,5% of the value $\pm 0,02$ % Measurement range 3: over 100%. Resolution: 5 digits; accuracy, typical: 0,5% of the value $\pm 0,03$ %; guaranteed: 0,8% of the value $\pm 0,05$ %
Power factor PF ($\cos(\phi)$)	<ul style="list-style-type: none"> Measurement range 1: from 0 to 10% (capacitive). Resolution: 5 digits; accuracy, typical: 0,05% of the value ± 0.005 %; guaranteed: 0,1% of the value $\pm 0,005$ % (from 45 to 70 Hz, current < 10 mA) Measurement range 2: from 0 to 100%. Resolution: 5 digits; accuracy, typical: 0,3% of the value $\pm 0,02$ %; guaranteed: 0,5% of the value $\pm 0,02$ %
Impedance	From 1 k Ω to 1.400 M Ω . Accuracy, typical 0,3% of the value $\pm 0,1\%$, guaranteed $< 0,5\%$ of the value. Resolution: 6 digits
Power (Dielectric Losses)	Measurement ranges: from 0 to 10 kW or 100 kW or 1 MW. Resolution (6 digits): 0,1 mW; accuracy: $< 0,5\%$ of the value ± 1 mW
Inductance	<ul style="list-style-type: none"> Measurement range 1: from 1 H to 10 kH. Resolution (6 digits): 0,1 mH; accuracy, typical: 0,3% of the value $\pm 0,5$ mH; guaranteed: 0,5% of the value Measurement range 2: from 100 H to 10 MH. Resolution (6 digits): 1 H; accuracy, typical: 0,3% of the value; guaranteed: $< 0,5\%$ of the value

Table 13- Derived measurements from the measurements of V and I

The same ranges and accuracies are applied to reactive and apparent power measurements.

3.3.1 Applicable test set

Tan(δ) measures can be executed on the following devices:

- Current Transformers
- Voltage Transformers
- Power Transformers
- Circuit Breakers

The tests are performed using the TDx 5000, and then connecting the high AC voltage source to test target.

Displayed parameters are the following:

- *Test type (1)*: Where the HV output is applied: in case of a specific device under test (CT, VT, PT or bushing, motors and generators), the options are displayed
- *Capacitance (2)*: In case of a specific device under test (CT, VT, PT or bushing), the options are displayed
- *Generation mode*: to execute a single shot, a voltage or a frequency gradient
- *Test mode*: It is selected in reference to the TD 5000 and the device under test connection. In case of a specific device under test (VT, in this case), the more correct test mode is automatically selected, considering also the selections (1) and (2)
- *Voltage/Frequency test table*: It allows to input the test voltage and frequency
- *Nominal Values*: Capacitance and TD reference values. In case of a specific device under test (CT, VT, PT or bushing), these values are kept from the related headers
- *Temperature compensation*: The Capacitance and TD values vary with the temperature: optionally, the “k” factor is used to compensate automatically the measures
- Test table
- Results table
 - Test voltage, current and frequency, excitation current
 - Capacitance, Tan(δ), power factor (PF)
 - Power (losses): active , reactive , apparent

Impedance: module, argument, components

The following table lists the parasitic capacitances which exist in a three winding (two secondary) power transformer, in a two winding (one secondary) power transformer and in a bushing transformer:

Transformer	Scheme	Terms
Three winding (two secondary) power transformer		<ul style="list-style-type: none"> • H = high voltage terminal • L = low voltage terminal • T = third winding • G = Ground • C(H-T): parasitic capacitance between High voltage and T • C(H-L): parasitic capacitance between High voltage and Low voltage • C(H-G): parasitic capacitance between High voltage and Ground • C(L-G): parasitic capacitance between Low voltage and Ground • C(L-T): parasitic capacitance between Low voltage and T • C(T-G): parasitic capacitance between T and Ground • C(H-Tap): parasitic capacitance between High voltage and Tap • C(Tap-G): parasitic capacitance between Tap and Ground • Test tap = test terminal
Two winding (one secondary) power transformer		
Bushing transformer		

Table 14 - Parasitic capacitances

Ratio test is performed by measuring a sample capacitance two times using the RTD option.

Voltage values up to 12 kV can be generated on the High Voltage side; Capacitance values on both High Voltage and Low Voltage sides are measured and then turn ratio is calculated using the ratio between them.

3.4 Display

The following image exhibits the TDx 5000 display:



Figure 6 - TDx5000 display

The following table lists the main features of the display:

Pixel	Light	LCD type	View area
640x480, colors	Backlight	TFT	132x99 mm

Table 15 - Main features of the display

3.5 Test control

Test control: by the START/STOP pushbutton. Pressing it, the output is generated, after test selection, according to the type of test. During ON.

3.6 Test saving

- Automatic save
- After operator confirmation

3.7 Menu selections

The following image exhibits the Home page of the test set of the Test Plan Editor:



Figure 7 – Home page

The menu is entered pressing the knob and selecting the item moving the knob.

The Test Plan Editor is an innovative and advanced software module, allowing the operator to define and plan a sequence of tests. The operator defines the desired sequence of tests and sets the parameters of each test: the Editor creates a sequence of tests to be performed automatically. The feature is available for the tests of Current, Voltage and Power transformers.

Test plans can be saved or recalled, like test results. Up to 64 settings can be stored and recalled; setting no. 0 is the default one, and pops up at power-on. Settings are permanently stored in the memory; new settings can be written to the same address after confirmation. For normal mode operation it is possible to recall the standard setting, which cannot be modified.

For instance, in the Home page select the icon “Current Transformers” and press the knob:



Figure 8 – “Current Transformers” icon

The following image exhibits the “Power Transformers – Header and Nominal Values” page (tab Description), visible at first time in which entering this section, or pressing the button “Header/Nominal Values”:

Figure 9 - "Current Transformers/Header and Nominal Values" page (tab Description)

The following image exhibits the tab “Nominals”:

#	Name	I Prim (A)	Nom Ik (A)	Nom Vk (V)
1	1S1-1S2	600.0	50.000m	400.000
2	1S1-1S3	300.0	43.300m	200.000
3	1S1-1S4	150.0	32.000m	100.000
4	1S1-1S5	100.0	10.000m	50.000

Figure 10 - "Current Transformers/Header and Nominal Values" page (tab Nominals)

These data are used as reference value for the assessment and as information in the test report.

The following image exhibits the tab "Tolerances":

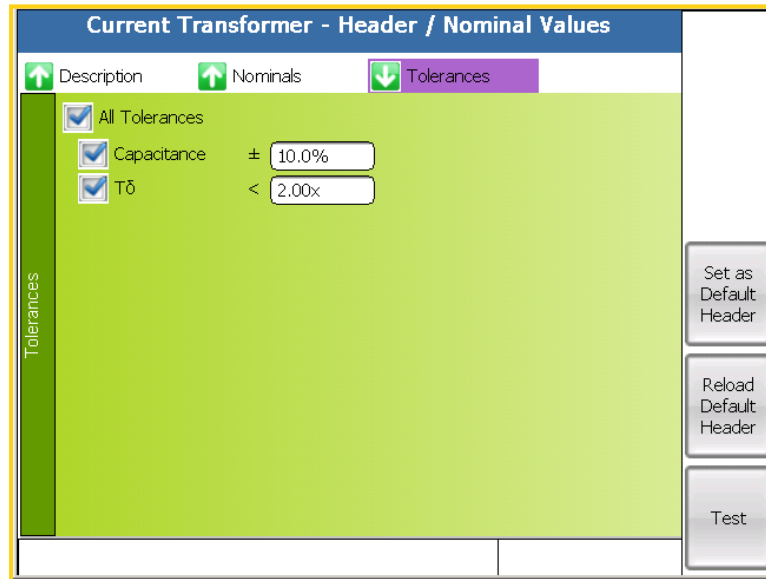

Figure 11 - "Current Transformers/Header and Nominal Values" page (tab Tolerances)

The page allows setting the tolerances for each of the available tests. If the tolerance is exceeded, the deviation is shown in the test result table.

After having set this basic information, pressing the shortcut "Edit Test Plan" at the side of the icon and enter the Editor mode; else, it is possible to continue with a single test.

The following image exhibits the "Power Transformers" test page:

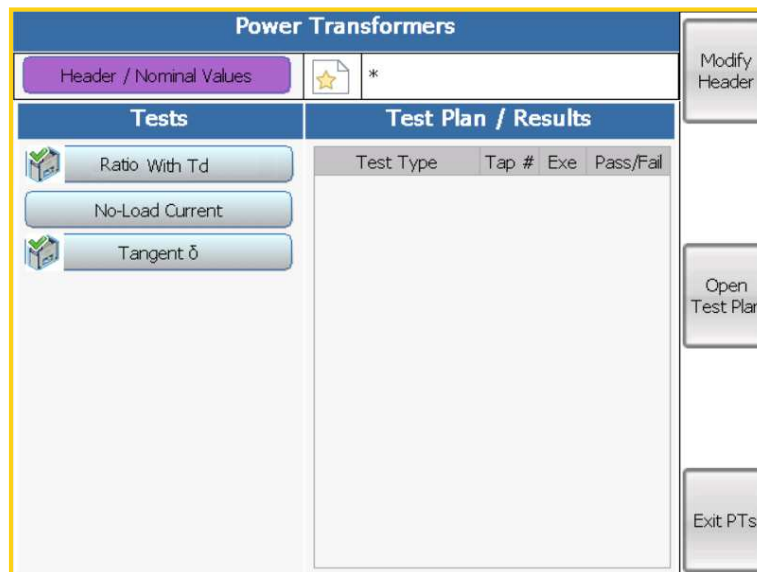

Figure 12 - "Power Transformers" test page

The page allows selecting the test to be performed: the corresponding window is opened, and test parameters can be programmed.

For instance, the following image exhibits the “PTs – Power Factor, Capacitance and Tan δ ” page:

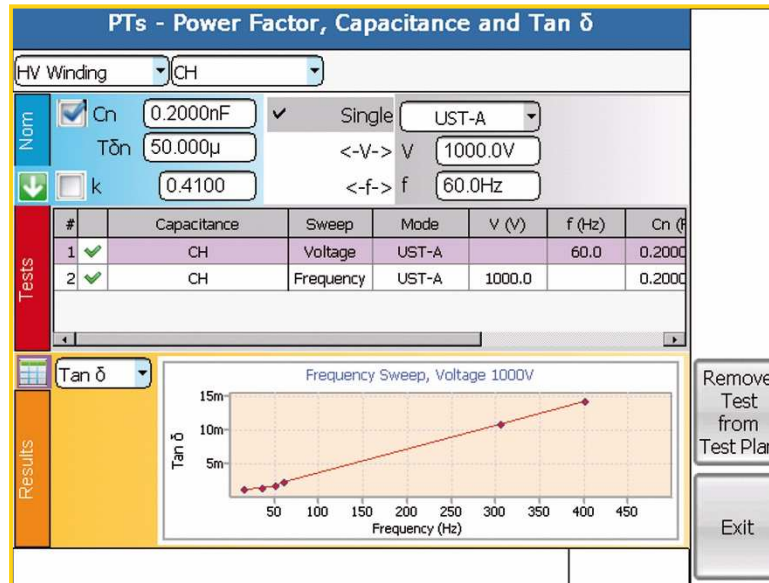

Figure 13 - "PTs – Power Factor, Capacitance and Tan δ " page

Customer can set different test, single shot, voltage sweep and frequency sweep (i.e.: voltage sweep, that is Tip Up or Down test). Selecting the test row and pressing start the test is automatically executed. At the end is possible to see directly on the screen numerical results and, for sweep test a graph of Tan δ or Capacitance as shown in picture. At the end is possible to save the test result inside the instrument memory or on an USB pen drive.

At the end of the tests, settings and results can be downloaded to a PC, with PADS program included in the TDMS suite, which comes with the device. The software allows saving test results into a file, examining them, printing them.

Optionally, PADS allows controlling the device from the PC. It is also possible to edit settings with PADS, and to upload them to TDx 5000.

In the picture above “k” is the temperature coefficient (5°C to 60°C, reference temperature 20°C) used to compensate the measures C and TD accordingly to the ANSI/IEEE C57.12.90 standard.

In the same test are calculated some equivalent parameters at different voltages (i.e. watt loss and current at 10 kV).

The Tan δ result can be displayed and calculated also as Power Factor, as absolute (0 to 1) or percentage values ((% value = abs value * 100), depending upon the selections in Software Settings panel:

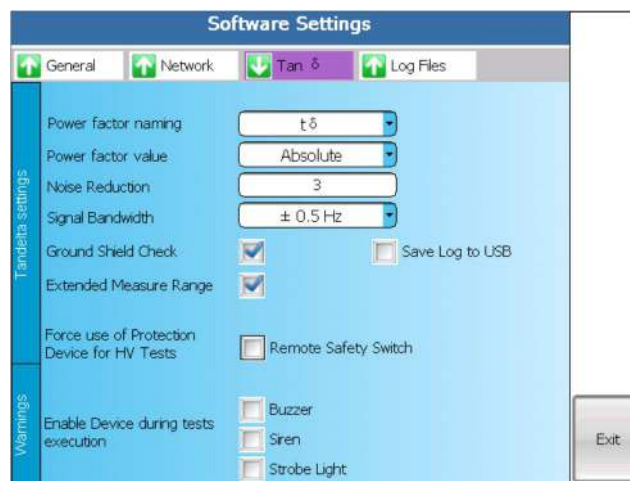

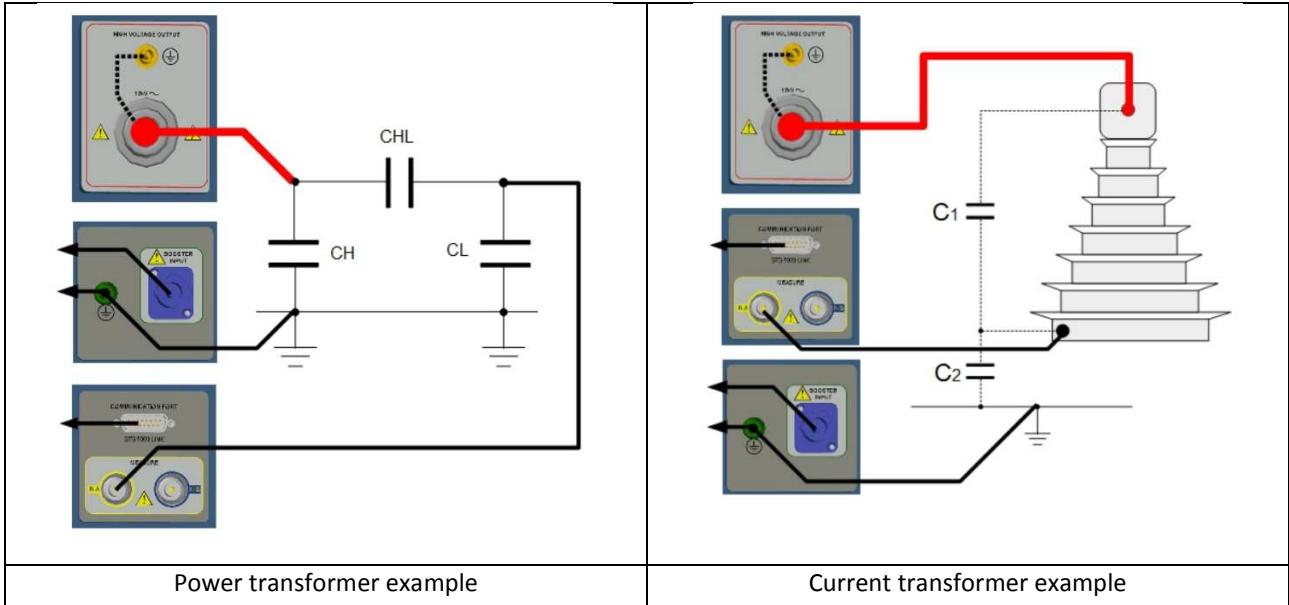

Figure 14 - "PTs – Software settings, Tan δ " page

If the operator have doubts regarding the connection between TDx5000 and the device under test, he can press the help button  and the connection scheme will be displayed as the folloing pictures below:



3.8 Standard connection cables (PII66175)

Connection cables differ somewhat as a function of the type of test set. The following table lists the provided cables:

Item	Description	Characteristics
1	No 1 Mains supply cable	Power cable 2m long, Schuko. Other plugs on demand (for example CEE, NEMA, CEI,BS, AS and others)
2	No 1 Grounding cable	6 m long, 6 mm ² , terminated on one side with a terminator, and on the other side with an earth connection clamp (No 2 cables for the option PII57175). Optionally a longer cable may be required
3	No 1 ETHERNET interface cable	
4	No 1 Operating manuals + Cd-Rom with TDMS	
5	No 1 USB pen drive	
6	No 1 yellow-green connection cable	6 m long, for the ground connections. Terminated with terminator on one side, and with a clamp on the other side
7	No 1 High voltage coaxial cable double shielded	20 m long, 25 kV, with earth screen, for the connection to the device under test. Terminated on the device side with an isolated tearproof plug or hook (option PII42185), and on the TDx 5000 side with two plugs: one for the HV and the other one for the ground
8	No 1 clamp	25 mm opening, with a connector which mates with the HV cable with 6 mm plug
9	No 1 bigger clamp	60 mm min. opening, with a connector which mates with the HV cable with 6 mm plug
10	No 2 Shielded connection cables	20 m long, for the connection to the metering points. Terminated on the TDx 5000 side with the metering connector, and on the device side with a plug. Cables are mounted on wheels
11	No 2 clamps	25 mm opening, terminated with sockets, which allow connecting to the metering point
12	No 2 Kelvin type clamps	60 mm opening, terminated with sockets, which allow connecting to the metering point
13	No 1 Hot Collar	Conductive rubber ribbon (1m) for insulation quality test
14	No 1 signals connection cable	To the EXT. DEVICES connector of TDx 5000, 1 m long
15	No 1 signals connection cable	To the EXT. DEVICES connector of S TDx 5000 , 2 m long
16	No 1 Transport Case	

Table 16 – TDx5000 provided cables

3.9 Other characteristics

The following table list other characteristics of the TDx 5000:

Item	Characteristic	Description
1	Memory	<ul style="list-style-type: none"> Up to 64 test plans More than 1,000 test results
2	Interfaces	<ul style="list-style-type: none"> ETHERNET for the PC connection. The Ethernet port can be used also for remote service and maintenance USB port for the USB key: this serves to download test settings and results
4	Other interfaces	<ul style="list-style-type: none"> Remote Start input. The test is started pressing the button on the option PII42175 Safety warning. It can be connected to the strobe with light PII43175. In case of alarm, the output drives the optional flashing siren and light
5	Mains supply	100÷230 V ±15% (85÷264 V); 47÷63 Hz . The instrument can be supplied with a portable generator without loss of performances.
6	Power consumption	Less than 1 kW in normal use; 1.8 kW (3,600 VA; 16 A) when generating the maximum power on High AC voltage output.
7	Dimensions	530 (H)x450 (W)x215 (D) mm TDx 5000 weight: 39 kg
8	Accessories	<ul style="list-style-type: none"> User manual, in English, Italian, French and Spanish No 5 spare fuses, type T16A Connection cables, provided in a case with handle and wheels

Table 17 - Other characteristics of the TDx5000

4 OPTIONS

4.1 Transport cases (code PII67175, PII66175)

The following image exhibits transport case (IP52) for TDx 5000 device.



Figure 15 - Transport case

Characteristic	Note
Handling	Handles on the top and on the side
Wheel	2
Dimensions	630 x 360 x 680 mm
Weight	13,1 kg

Table 18 – Transit case main characteristics

The following image exhibits transport case (IP67) for TDx 5000 cable set:



Figure 16 - Transport case cable set

4.2 PADS licence (code PII10176T)

The software PADS allows connecting TDx 5000 to the PC.

Software features are the following:

- To download from the test set test results and settings, and to save them into a file in order to have an history of the test executed on the asset
- To open and save or export test results in the formats: XLSX (EXCEL), CSV , Doc , RPT , PDF , JPEG and XML.
- To display in real time, the measurements performed by the test set, with possibility to pause the test (when applicable)
- To display, save and print test results diagrams
- To zoom and compare different curves of more than one result
- To edit, display and print the test report, with the following information:
 - Place, substation name, line, phase, model, serial number, operator, date and time
 - Nominal values: type of device, power, primary and secondary voltage or current
 - Parameters tolerances
 - For PT's: nominal tap voltages
 - Test result table, with comments about the test results OK or NO
 - Notes and comments

The program allows also to do the following:

- Upload or download test settings
- Upload or download test set calibration parameters

PADS software is subject to license:

- PADS Software Transformer - Power Transformer and Tan(δ) Modules



ATTENTION: The software runs with any WINDOWS® environment.
Windows, EXCEL and Access are trademarks of Microsoft Corporation

4.3 Remote Safety Switch (code PII42175)

The following image exhibits the Remote Safety Switch:



Figure 17 - Remote Safety Switch

When the Remote Safety Switch is connected and enabled, it avoids any current or voltage generation from pressing START/STOP button on the STS only.

The cable length is 20 m.

4.4 Warning Strobe Light (code PII43175)

The following image exhibits the Warning Strobe Light:



Figure 18 - Warning Strobe Light

The Warning Strobe Light alerts when the test is performed. A siren is also included for audible alerts when the test is performed.

It has to be connected to the Safety Warnings (14) connector.

4.5 RCTD reactor for motors and generators measures (code PII47175)

This option applies to TDx 5000 and allows increasing the test current and getting the maximum test voltage on high capacitive burdens.

The following image exhibits the RCTD option:



Figure 19 - RCTD option

Each RCTD is composed by two inductors with a nominal value of 40 H and a steady current of 0,6 A.

The maximum current on each inductor can be up to 1 A for more a limited time.

The inductors can be connected in parallel on the load in order to increase the test frequency.

It is possible to connect two RCTD in parallel in order to have three or four inductors connected in parallel.

The following table lists the RCTD characteristics:

Characteristic	Value
Weight	39 kg
Dimensions	23 x 44 x 28 mm

Table 19 – RCTD characteristics

The reactor has a standard cable kit (code PII48175) and the following table lists them:





Cable	Characteristics	Scheme
N. 1 ground cable	6 m long, 6 mm ² terminated with terminator and clamp	
N. 1 safety cable	To TDx 5000; 10 m long, 2x0,5 mm ²	
N. 1 "Safety IN" connector	For the safety loop closure	
N. 1 Safety cable	To connect another RCTD; 2 m long, 2x0,5 mm ²	
N. 1 clamp	Screw terminal, with plate for the HV connection	
N. 2 HV cables	5 m long, not shielded, terminated with 6 mm male connectors	

Table 20 – RCTD cables

4.6 CAP-CAL reference capacitor (code PII40175)

The following image exhibits the CAP-CAL reference capacitor:

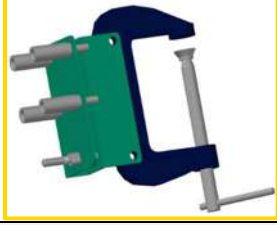

Figure 20 - CAP-CAL reference capacitor

Purpose of the reference capacitor is to check the actual calibration of TDx 5000 for the measures of the capacitance and Tan δ .

The CAP-CAL includes an extremely high accuracy high voltage and low Tan δ capacitor. The device includes also 4 resistances to be connected to the capacitor in series mode, to generate some known Tan δ values.

The following image exhibits the connection of the CAP-CAL to the TDx 5000:

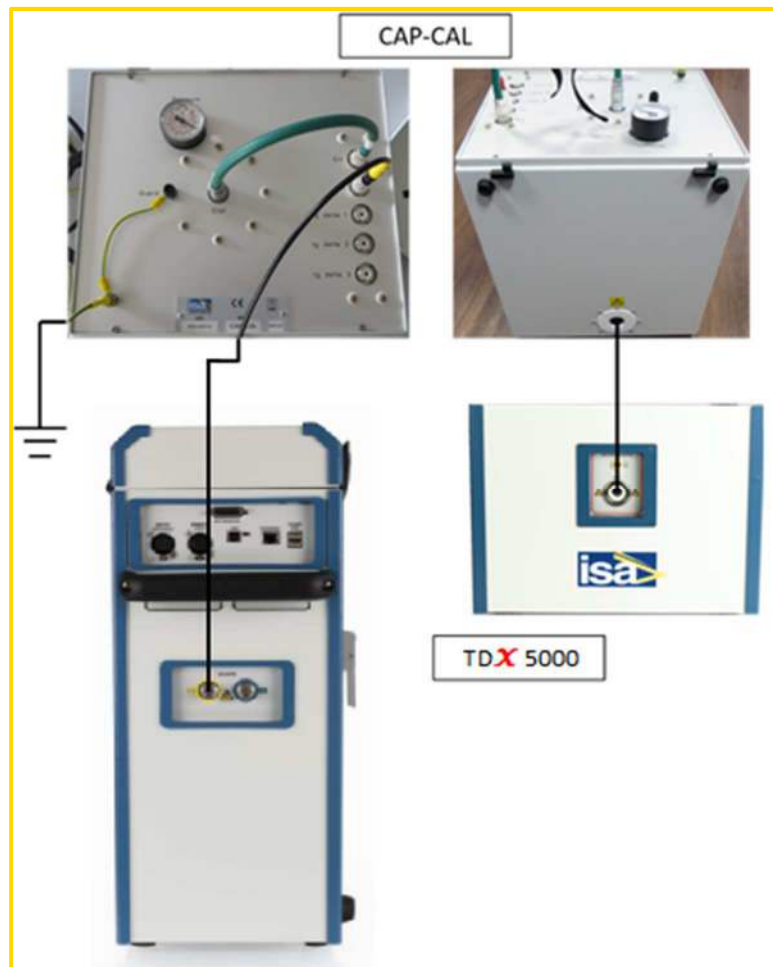

Figure 21 - Connection of the CAP-CAL to the TDx5000

A calibration certificate is issued by ISA laboratory and it is supplied together the CAP-CAL.

4.7 STOIL cell for the insulating oil check (code PII13175)

This option applies to TDx 5000, to perform Tan δ , Power factor and capacitance test of the PT oil or other insulation liquids.

The following image exhibits the STOIL option:



Figure 22 - STOIL option

Cell characteristics are the followings.

- Maximum test voltage: 12 kV
- Cell volume: 1 l
- Empty cell capacity: (60±10) pF

The option comes complete with the following connection cables: No. 2 HV connection cables, 2 m long, terminated on the TDx 5000 side with the HV connector, and on the other side with the proper termination for the cell.

4.8 Digital Thermo Hygrometer (code PII44175)

The following image exhibits the Digital Thermo Hygrometer:



Figure 23 - Digital Thermo Hygrometer

Some tests performed by TDx 5000, such as Tan δ , are influenced by temperature and humidity. The option allows measuring these parameters, and to input them into the test settings.

The following table lists the main characteristics:

Characteristic	Value
Temperature range	(-10÷+60) °C (-50÷+250) °C with an external sensor
External temperature sensor	RTD Ni1000/6180 ppM, not included
Temperature measurement accuracy	±0.4 °C
Humidity measurement range	(5÷95) % RH
Resolution of humidity measurement	0.1%
Accuracy of humidity measurement	±2,5% RH over the whole range
Battery	9 V
Battery life	Typically, 9 months
Dimensions	(141x71x27) mm
Weight	150 g

Table 21 - Digital Thermo Hygrometer main characteristics

4.9 RTD Capacitance for transformer ratio at high voltage (Code PII41185)

This option allows using high voltage generator TD 5000 to measure the turn ratio of the transformers.

Voltage values up to 12 kV can be generated and turn ratio precision is 0.1 %



Figure 24 – RTD Capacitance

4.10 Hook for HV connection (Code PII42185)

Optionally in the cable set could be included an hook that can be connected the high voltage cable: length 250 mm and internal diameter 100mm.



Figure 25 – Hook for HV connection

4.11 IN-A and IN-B current measure inputs up to 10A (Code PII50185)

Optionally IN-A and IN-B current inputs can measure up to 10A for a maximum of 10s. These inputs have the same characteristics as for standard inputs 5A, refer to chapter 3.3. This option must be selected at the order.

5 PROTECTIONS

The protections of the TDx 5000 are the following:

- If the test set is not connected to the ground, the test set does not allow for power generation, and warns the operator with a diagnostic message and a fixed led light
- Fuse on the mains supply
- At power-on, a diagnostic sequence controls
 - Key microprocessor board components
 - Auxiliary supply voltages.

If something is wrong, the operator is alerted by a message.

- Emergency pushbutton: if pressed, all main outputs are removed
- The high voltage output has the following protections
 - Confirmation key: if not turned, the HV output is not generated
 - The HV is generated only if selected; the HV selection is confirmed by warning lights
- Thermal sensor on the main transformer. In case of over-temperature, an alarm message is displayed
- Thermal sensor on the active electronic devices. In case of over-temperature, an alarm message is displayed
- If maximum current limits and time duration of power transformer generators are trespassed, the generation is interrupted, and the operator is warned by an alarm message
- The current measurement input is protected against wrong connections

Page left intentionally blank.

REVISIONS

The following table lists the revisions of the document:

No.	Date	Description
1	January 2016	First issue
2	February 2018	Minor changes on pages 14 and 15.
5	September 2020	Complete review
6	September 2020	RTD option added
7	September 2021	Minor tips and options 4.10 and 4.11 added

Table 22 - Revisions

Page left intentionally blank.

LIST OF FIGURES

FIGURE 1 - TDx 5000.....	9
FIGURE 2 - TEST SET FRONT PANEL	10
FIGURE 3 – LEFT PANEL COMPONENTS	12
FIGURE 4 - RIGHT PANEL COMPONENTS.....	13
FIGURE 5 -REAR PANEL	14
FIGURE 6 - TDx 5000 DISPLAY.....	20
FIGURE 7 – HOME PAGE	21
FIGURE 8 – “CURRENT TRANSFORMERS” ICON	21
FIGURE 9 - "CURRENT TRANSFORMERS/HEADER AND NOMINAL VALUES" PAGE (TAB DESCRIPTION)	22
FIGURE 10 - "CURRENT TRANSFORMERS/HEADER AND NOMINAL VALUES" PAGE (TAB NOMINALS)	22
FIGURE 11 - "CURRENT TRANSFORMERS/HEADER AND NOMINAL VALUES" PAGE (TAB TOLERANCES).....	23
FIGURE 12 - "POWER TRANSFORMERS" TEST PAGE	23
FIGURE 13 - "PTs – POWER FACTOR, CAPACITANCE AND TAN Δ" PAGE	24
FIGURE 14 - "PTs – SOFTWARE SETTINGS, TAN Δ" PAGE	24
FIGURE 15 - TRANSPORT CASE	28
FIGURE 16 - TRANSPORT CASE CABLE SET	28
FIGURE 17 - REMOTE SAFETY SWITCH	29
FIGURE 18 - WARNING STROBE LIGHT	30
FIGURE 19 - RCTD OPTION	30
FIGURE 20 - CAP-CAL REFERENCE CAPACITOR.....	31
FIGURE 21 - CONNECTION OF THE CAP-CAL TO THE TDx 5000	32
FIGURE 22 - STOIL OPTION.....	33
FIGURE 23 - DIGITAL THERMO HYGROMETER.....	33
FIGURE 24 – RTD CAPACITANCE	34
FIGURE 25 – HOOK FOR HV CONNECTION	34

LIST OF TABLES

TABLE 1- OPTIONAL MODULES	7
TABLE 2 - FRONTAL PANEL COMPONENTS (1/2)	10
TABLE 3 – LEFT PANEL COMPONENTS.....	12
TABLE 4 – RIGHT PANEL COMPONENTS	13
TABLE 5 – RIGHT PANEL COMPONENTS	14
TABLE 6 – STANDARDS RELATED TO THE EMC DIRECTIVE	15
TABLE 7 - STANDARDS RELATED TO THE LV DIRECTIVE	15
TABLE 8 - HV GENERATOR MAIN CHARACTERISTICS.....	16
TABLE 9 – FREQUENCY RANGE ON ALL THE AC OUTPUTS	16
TABLE 10 – OTHER FEATURES OF MAIN OUTPUTS.....	16
TABLE 11- VOLTAGE AND CURRENT OUTPUT MEASUREMENT ACCURACY AND RESOLUTION	17
TABLE 12- FREQUENCY CHARACTERISTICS OF TD 5000.....	17
TABLE 13- DERIVED MEASUREMENTS FROM THE MEASUREMENTS OF V AND I	18
TABLE 14 - PARASITIC CAPACITANCES	19
TABLE 15 - MAIN FEATURES OF THE DISPLAY	20
TABLE 16 – TDx 5000 PROVIDED CABLES	26
TABLE 17 - OTHER CHARACTERISTICS OF THE TDx 5000	27
TABLE 18 – TRANSIT CASE MAIN CHARACTERISTICS.....	28
TABLE 19 – RCTD CHARACTERISTICS.....	30
TABLE 20 – RCTD CABLES.....	31
TABLE 21 - DIGITAL THERMO HYGROMETER MAIN CHARACTERISTICS	34
TABLE 22 - REVISIONS	37

ISA HEADQUARTER

I.S.A. – Altanova Group S.r.l.

via Prati Bassi 22, 21020 Taino (Va) – ITALY

Phone +39 0331956081

Fax +39 0331957091

Email isa@altanova-group.com

REGIONAL OFFICES

ISA ADVANCE INSTRUMENTS (I) Pvt. Ltd.

C-33, Ground Floor, Sector-2, NOIDA-201

301, Uttar Pradesh, INDIA

Phone +91120 4543853 / 54 / 4222712

Fax +91120 4574772

Email: info.asia@altanova-group.com

ISA PACIFIC PTE Ltd

61 Ubi Rd 1, #03-29A, Oxley Bizhub

Singapore, 408727

Phone +65 62782381

Email: ivan.chan@altanova-group.com

ALTANOVA GROUP SOUTH AMERICA

São Paulo, BRASIL

T +5511 96335 - 3518

Email: ronaldo.arregalo@altanova-group.com

ALTANOVA GROUP CENTRAL AMERICA

Villas Alpinas, 8th Street, #88D

T +507 65503173

Email: diogenes.quintero@altanova-group.com

ALTANOVA GROUP GCC

Office no 713, Business Avenue Building Port Saeed Road, Dubai - United Arab Emirates

Phone: +971 55 5146998 / +971 55 5165793

Fax: +971 42956099

Email: imteyaz.siddiqui@altanova-group.com

TECHIMP GERMANY GMBH

Feldstraße 23,31691 Helpsen

Germany

T: +49(0)1702364735

Email: martin.hesse@altanova-group.com

ALTANOVA GROUP FRANCE & MAGHREB

Paris, France

T: +33 6 73691137

Email: fabien.causse@altanova-group.com



