

Critical Asset Monitoring

Low-Profile Temperature Sensors

The IntelliSAW temperature sensors are the ideal method for real-time, continuous monitoring of low and medium voltage critical asset hot-spots such as bus bars, breaker arms, breaker contacts, and cables.

Surface acoustic wave (SAW) technology enables a 100% wireless, passive (no power required) continuous temperature monitoring sensor. The SAW sensors were specifically designed for electrical power assets with basic insulation levels (BIL) up to 185kV.



Features

- 100% passive. No power source required
- Designed and type tested for low and medium voltage applications
- Small, simple to fit existing asset structures
- Low-profile design ideal for breaker arm installation
- 20+ year operational life expectancy

Applications

The Integrated Antenna SAW Sensors are the most reliable method of thermal monitoring in a wide range of electrical power critical asset applications including switchgear, breaker arms, bus ties, bus ducts, transformers, and generator circuit breakers.

The sensors seamlessly interface to all IntelliSAW Critical Asset Monitoring systems and provide up to twelve measurement locations per asset.

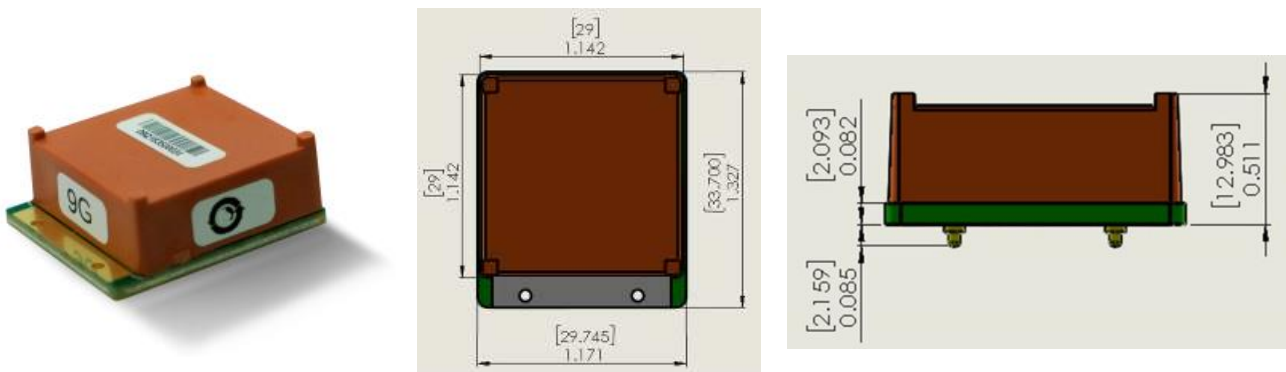

Specifications

Temperature Measurements

Range	-25°C to +155°C
Resolution	± 0.2°C
Accuracy	
Standard Range (0 to 80°C)	± 2°C
Full Range	± 4°C
Number of Sensor Channels	12 (non-overlapping channels)
Sensor Frequencies	Between 425 MHz to 442 MHz

Physical

Cover Material	Polyphenylene Sulfide (PPS)
Ingress Protection (IEC 60529)	IP 30
Cover Dielectric Strength	18 kV
Dimensions	29.7 W x 33.7 L x 13.1 H (mm)

Mounting

Recommended Mounting	Cable Tie: 5.5 W x 1.65 mm Thick (Max) Non-conducting ETFE, 150oC operating temperature (McMaster-Carr 70215K93) Bonding Tape 3M VHB 4646 Bonding Tape (150oC operating temperature)
----------------------	---

Safety

IntelliSAW systems are installed in close proximity to medium and high voltage electric power equipment. Qualified personnel need to observe industry standard safety practices that will protect the systems and operators from harm due to induced voltages. Proper antenna installation and system safety grounding is crucial to operator safety and system reliability.

Model numbers

Not all model combinations are stocked. Please contact sales before ordering.

Sensor Family (SF)

LP: Low-Profile SAW Sensor



Frequency Band (F)

01: Band 01	04: Band 04	07: Band 07	10: Band 10
02: Band 02	05: Band 05	08: Band 08	11: Band 11
03: Band 03	06: Band 06	09: Band 09	12: Band 12

When commissioning a system, care must be taken not to duplicate same sensor frequency bands within a given asset. IntelliSAW recommends selecting sensors based on their groupings for optimal performance. Please contact sales for more details.

SENSOR GROUPING

01, 03, 05

02, 04, 06

07, 09, 11

08, 10, 12

Homologation

System integrators and installers are responsible for adhering to all regional regulations concerning the import, installation and operation of IntelliSAW Critical Asset Monitoring systems.

Suitable For

BUSBARS

BREAKER ARMS

BREAKER CONTACTS

CABLES

ALTANOVA
GROUP

www.altanova-group.com

TECHIMP

TECHIMP - ALTANOVA GROUP
Via Toscana 11,
40069 Zola Predosa (Bo) - Italy
T +39 051 199 86 050

Email sales@altanova-group.com

isa

ISA - ALTANOVA GROUP
Via Prati Bassi 22,
21020 Taino (Va) - Italy
T +39 0331 95 60 81
Email isa@altanova-group.com

IntelliSAW

IntelliSAW LLC - ALTANOVA GROUP
100 Burr't Rd
Andover, MA 01810 (USA)
Phone +1 978-409-1534
Email contact@intellisaw.com